



A B S A U G W E R K

DEDUSTER

P SERIES | S SERIES



The WERK

As a manufacturer of industrial extraction technology, we strive for a clean and healthy working environment. Our strength lies in the in-house development and production of customised extraction systems designed to protect employees, machines and workpieces.

From industrial dedusters and oil mist separators to complete hall extraction systems, we offer a comprehensive portfolio of solutions. We combine capture elements, extraction units and pipe systems into an integrated overall system that sets new standards in terms of energy efficiency and performance. In the field of explosion and fire protection, we are one of the few providers that fully meet all legal requirements and are able to ensure safe operation. With our many years of expertise, we develop special solutions for companies of all sizes and across all industries.

The production of our high-end systems takes place at our own WERK. Here, quality and precision are our top priorities. We support our customers throughout the entire service chain – from initial consultation through to installation and beyond. This ensures that their systems always operate at optimum performance.

Our network is particularly close to our hearts. Built on honesty and trust, we create long-term partnerships that lead to shared success.

»People, as customers, partners or employees, are always at the heart of our company.«

Michael Werz, Managing Director

Introduction	1
←—————	
Deduster	3
Applications & components	5
Functionality	7
The ABSAUGWERK Principle	8
Accessories & options	9
Sustainability	16
Explosion protection	17
Fire protection	19
Noise protection	21
Technical data	23
Reference	25
—————→	
All-round service	29
Quality	31
Training & partnership	33
Project process	34





The dust collector product video at absaugwerk.de/en/deduster

The invisible danger!

PROBLEM

Whether grinding, deburring, cutting or sandblasting – dust is generated wherever materials are processed. Visible deposits are only the tip of the problem: hazardous fine dust particles remain suspended invisibly in the air for hours, are re-circulated with every movement and penetrate deep into the respiratory tract, where they can hardly be broken down. The consequences range from chronic respiratory diseases and allergic reactions to, in the worst case, cancer.

Around *6.000 cases of illness** caused by dust and fume exposure in the workplace are recorded in Germany every year. However, it is not only employee health that is at risk. Deposits on machines, pipe system and control systems impair production and lead to increased maintenance requirements or even system failures. In addition, many types of dust – such as aluminium, copper or flour dust – are considered combustible or explosive and therefore pose a significant safety risk.

Controlled air capture and filtration are therefore essential to ensure long-term protection of health, product quality and operational safety.

** Source: Federal Institute for Occupational Safety and Health (BAuA), BIBB/BAuA Employment Survey 2020*

DEDUSTER

P Series | S Series



SOLUTION

To effectively reduce exposure to fine dust and particles, our high-performance dedusters are used. They capture contaminated air directly at the source, filter even the finest particles and return the cleaned air to the production hall or safely discharge it outside.

The ABSAUGWERK dedusters of the P Series (*cartridge filters*) and S Series (*hose filters*) can be individually configured and are suitable for a wide range of materials – from fine dust to coarse chips. Automatic jet pulse filter cleaning continuously removes dust deposits from the filters, extends their service life and significantly reduces maintenance and operating costs. For processes involving particularly critical substances such as stainless steel or glass, an integrated HEPA H14 filter ensures maximum air purity and reliable occupational safety.



Performance:

2,400 – 36,500 m³/h*

1.1 – 45 kW

** Systems connected in series have the potential to deliver virtually unlimited performance.*

Your benefits

High extraction power

Low energy consumption

Cleanable permanent filters

Durable filter components

Easy cleaning & maintenance

Individual configuration & special solutions

Recirculating air & exhaust air operation

Versatile control functions

Remote maintenance & remote access

Exclusive design

Application

During grinding, deburring, cutting or polishing, fine dusts, chips and particles are generated and dispersed into the hall air, affecting both employee health and the service life of machines. Especially when processing aluminium, stainless steel or plastics, hazardous fine dusts may be released, some of which are explosive or carcinogenic.

INDUSTRIES

Automotive, chemical industry, food industry, metal processing, pharmaceutical industry, plastics & recycling industry, mechanical engineering, etc.

PROCESSES

- Sawing
- Separating
- Grinding
- Polishing
- Deburring, etc.

MEDIA

- Dust
- Chips
- Granules
- Fibres
- Flakes
- Lint



Filters:

- Cartridge filters
- Hose filters

Discharge:

- Drawer
- Bin
- Bucket
- Container
- Automatic discharge (*rotary valve*)
- Individual discharge

Capture:

- Extraction arm
- Extraction table
- Extraction hood
- Pipe system
- Machine connection
- Room capture
- Individual capture

Equipment:

- 15 power levels
- Multiple filter stages for max. degree of separation
- Jet pulse filter cleaning
- IE3 to IE5 motors

Components

ABSAUGWERK dedusters capture dust using individually designed capture systems and reliably separate it using cartridge or hose filters. When dealing with carcinogenic substances such as stainless steel, a HEPA H14 filter provides additional safety. Efficient fans and precisely matched components ensure maximum performance with minimal energy consumption. Optionally, the system can be equipped with a powerful high-pressure fan.

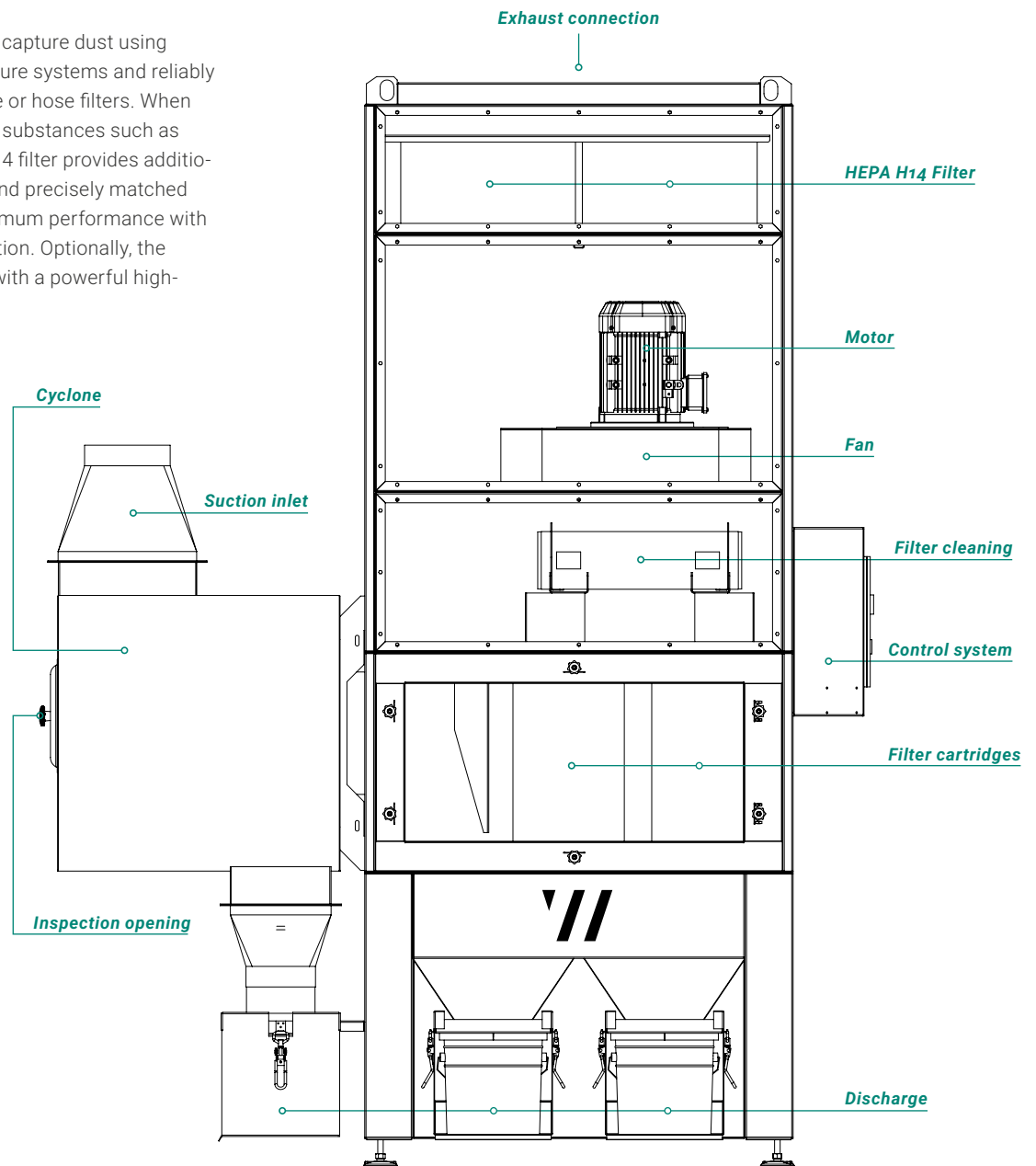

Options:

- HEPA H14 filter for carcinogenic substances in recirculating air operation
- Activated carbon filter for gases and odours
- ATEX / fire protection version
- Pre-separator
- Stainless steel version
- Effective noise protection
- Cross-flow heat exchanger
- Precoat unit
- Various fans
(medium pressure, high pressure)
- Versatile intelligent controls
- Individual system colour & branding



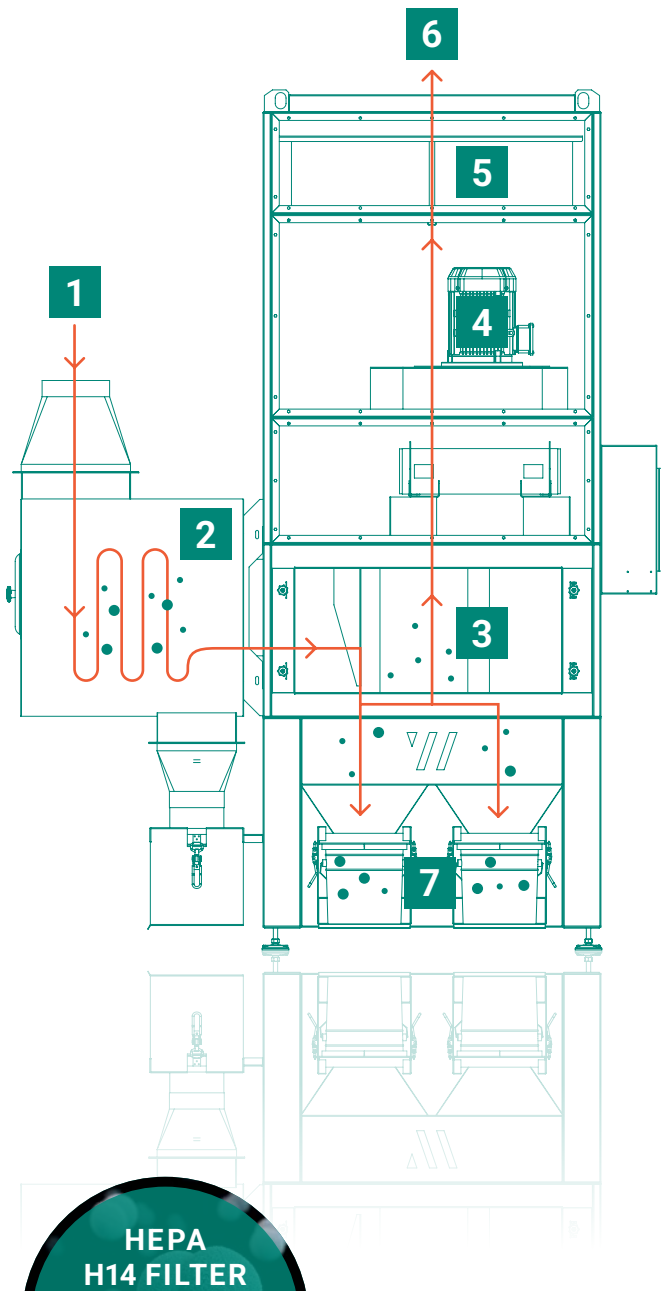

Functionality

The air is captured directly at the source, filtered in several stages and cleared of dust, chips and fine particles. It can then be safely returned in recirculating air or exhaust air operation.

1. SUCTION

Contaminated air is extracted via a direct machine connection or another capture system.

2. PRE-SEPARATOR

A pre-separator removes a large proportion of medium-sized and coarse particles, chips and sparks at an early stage. This protects the main filters and significantly extends their service life.

3. FILTER STAGE 1

Fine dust is reliably separated using cartridge or hose filters. Filter cleaning is carried out automatically via jet pulse cleaning.

4. FAN

The fan with IE3 technology, optionally available with IE4 or IE5, operates extremely quietly, efficiently and with high performance.

5. FILTER STAGE 2

For particularly fine or carcinogenic substances such as stainless steel, an additional HEPA H14 filter is used to reliably capture even microscopic particles.

6. EXHAUST

The cleaned air is either discharged outside or returned to the room in recirculating air operation, reducing heating and energy costs.

7. DISCHARGE

The separated dust is disposed of individually via drawers, bins, buckets or containers. Alternatively, automatic discharge is carried out via a rotary valve.

HEPA H14 FILTER

Filters 99,995% of all fine particles and viruses

With a separation efficiency of 99.995%, HEPA H14 filters remove even ultrafine and carcinogenic particles from the air. They ensure maximum safety in processes involving stainless steel or other hazardous substances.

The ABSAUGWERK Principle

A high-performance and energy-efficient extraction system consists of several components that must work in perfect harmony. If elements such as capture systems or the pipe system reduce performance, this can not only impair functionality but also lead to deposits and dangerous fires. As every application is unique, we develop and manufacture customised extraction systems tailored precisely to our customers' requirements. For an optimal extraction solution, we also take care of pipe system design, installation and, optionally, maintenance and after-sales service.

Everything from a single source directly from our WERK.

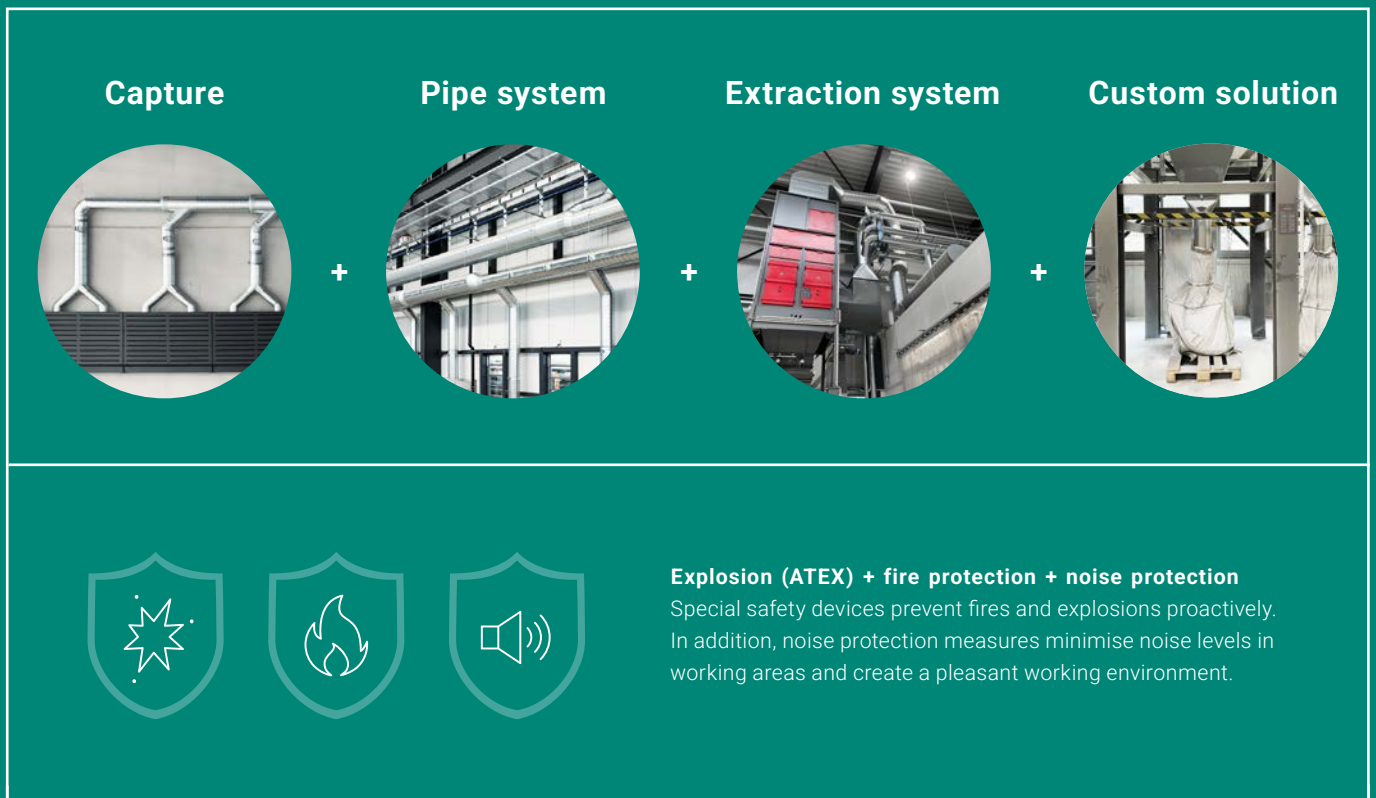

Where standard ends,
we begin!

The result is a holistic extraction solution from start to finish. This increases performance while reducing long-term operating costs for maintenance and energy, without compromising productivity. It makes our systems a sustainable and cost-effective investment.



Accessories & options

To configure the right extraction system for every application, we offer a wide range of accessories and options for our extraction systems. These include capture elements for precise emission extraction, various discharge options for safe material disposal, efficient pipe systems for optimal airflow, precoat units for filter protection as well as pre-separators, to extend filter service life.

This wide range of options provides maximum flexibility and adaptability to meet specific requirements such as process, material and environment, ensuring reliable air cleaning.

Capture systems,
discharge solutions,
pre-separators,
precoat units, pipe
systems, etc.

Available in numerous
sizes & variants!



Extraction arms

Extraction arms are used for the local capture of emissions directly at the point of origin. The flow-optimised design with low resistance prevents deposits and ensures consistently high extraction performance. Particularly smooth-running joints allow easy and precise positioning. Ergonomic handles, a large working radius, as well as optional switches, LED lighting and various capture hoods provide a high level of operating comfort.



Extraction hoods

Overhead hoods are used for rising media with small particle sizes. They are available in various sizes with different mounting systems and accessories such as louvers or spark arresters.

Side hoods are ideally suited for horizontal or lateral emission sources. The rectangular hoods are versatile in use and can be operated open or equipped with protective or deflection plates.



Extraction tables

Extraction tables are used as workbenches for tasks such as grinding, sawing or welding. They safely and efficiently capture dust, fumes or chips directly at the source. Coarse material falls directly downwards into a discharge bin, while fine particles are captured via the rear or side panels and filtered in an extraction system. Thanks to the flexibly foldable side panels, even large workpieces can be processed without difficulty.

The WT Series extraction tables are ergonomically designed and available in various sizes. They offer numerous options such as LED lighting (also ATEX), hydraulic height adjustment, wheels for mobile use, tool holders, a roof or vice mount. Generous legroom and comfortable operation make them the ideal workbench for clean and safe processing.

Height-adjustable workbench

Ergonomic with generous legroom

Ideal for small series & special parts

Flexibly foldable side panels

Easy discharge & disposal

Individually configurable & expandable

Various worktop options available

Quality »Made in Germany«

WT Series extraction tables are available with various worktop options:



Grating



Plastic



Plasma



Wood

Pre-separators

Pre-separators capture sparks and coarse particles upstream of the filter unit and remove a large proportion of medium-sized and coarse dust at an early stage. This significantly relieves the load on the main filter unit, extends filter service life and noticeably reduces follow-up costs.

ABSAUGWERK pre-separators are suitable for all system types, easy to retrofit and available in various designs. They deliver maximum extraction performance with minimal energy consumption, ensuring efficient and safe extraction over the long term.



STANDALONE CYCLONE PRE-SEPARATOR

The cyclone pre-separators have been developed using modern flow simulation to achieve optimal airflow velocity and maximum extraction performance. They are available in several versions and can be installed independently next to the system.



SIDE-MOUNTED CYCLONE PRE-SEPARATOR

The side-mounted cyclone pre-separator impresses with its compact and robust design and can be installed directly on the system. It reliably separates coarse particles and sparks, protects the filter system and ensures a longer filter service life.



SPARK PRE-SEPARATOR

The spark pre-separator is installed between the capture system and the pipe system. Due to the reduced air velocity, sparks cool down and are extinguished before reaching the filter system. This minimises the risk of fire and increases operational safety.

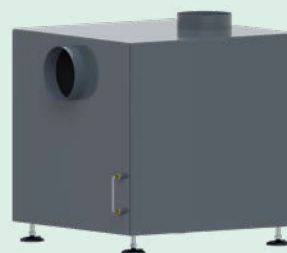

WET PRE-SEPARATOR

In the wet pre-separator, fumes, dust and sparks are bound in a water bath and almost completely extinguished. This reliably protects the extraction system and ensures a high level of operational safety.



Custom pre-separator solutions

When processes impose special requirements, customised solutions such as zig-zag pre-separators are required. These deflect sparks and particles several times, causing them to lose energy and extinguish.

In addition, non-return dampers can be combined with the filter system. They prevent dust or odours from flowing back during filter cleaning or system shutdown, ensuring smooth and clean operation.

Every system is different! We are happy to advise you and develop your customised solution.



Deduster with standalone cyclone pre-separator and automatic discharge via a rotary valve

Discharge systems

The captured media are conveyed to the extraction system via a flow-optimized duct system, where they are filtered in multiple stages, while the residual material is safely discharged via a suitable disposal system. Our standard systems can be flexibly expanded with customized solutions tailored to the process, material behavior, and available space.

Depending on the configuration, emptying is either interval-controlled or monitored via level sensors. When the container is full, a notification is automatically issued and the system is safely shut down. This prevents overfilling and ensures long-term operational safety.

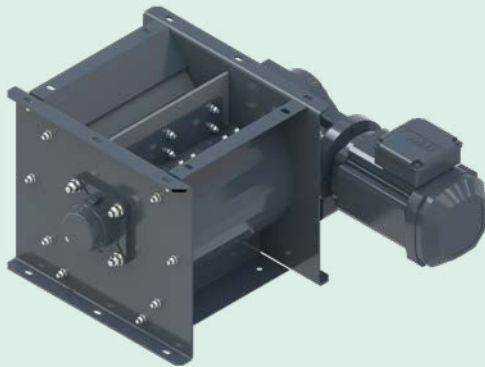

ROTARY VALVE

Automatic discharge systems such as rotary valves, double pendulum flaps, screw conveyors, pneumatic conveying systems, discharge slides or shut-off dampers enable time- or quantity-controlled emptying. Discharge can be carried out intermittently or continuously, ensuring reliable continuous operation even with large material volumes.

DRAWER

The drawer discharge is integrated directly into the system, allowing for a particularly compact design. It is ideally suited for very small discharge volumes that can be emptied quickly.

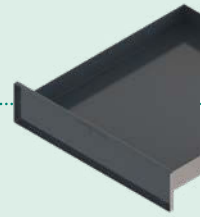

BUCKET

Dust collection buckets with a capacity of 15 or 30 litres offer increased volume and are designed for dust-free disposal thanks to a sealable lid. They are the right choice for small to medium material quantities.



BIN

Bins offer significantly larger capacity and are available in numerous variants – with liner bags, forklift pockets or a tilting mechanism. They are ideally suited for larger material volumes and convenient emptying.



CONTAINER

Containers are designed for very large discharge volumes and are often combined with automatic discharge solutions. They provide efficient and safe disposal, even with high material volumes. Optionally available with oil sieve, tilting device, or rollers for easy transport.



DISCHARGES	R 2000	R 3000	R 4000	R 5000	R 6000	R 7000	R 8000
Drawer 50 L	●						
Dust collection bin 50 L	●	●	●				
Dust collection bin 100 L		●	●	●	●	●	●
Bucket 1 x 15 L	●						
Bucket 2 x 15 L		●	●	●	●	●	●
Bucket 2 x 30 L		●	●	●	●	●	●



Extraction cabins

Extraction cabins enable particularly efficient and energy-saving capture, as only a limited air volume needs to be circulated and filtered. Crossflows caused by doors, windows or movements within the hall are significantly reduced, resulting in much more stable capture performance. At the same time, *statutory workplace exposure limits** statutory workplace exposure limits* can be met more easily and cost-effectively. Noise and heat generated by many processes are also effectively contained within the cabin and continuously reduced.



Hall extraction

For large production areas, hall extraction with a central system and pipe system provides comprehensive air cleaning. Multiple workstations can be captured simultaneously and the entire hall air is continuously filtered. This enables the efficient removal of high pollutant loads. In recirculating air operation, the system operates particularly energy-efficiently and sustainably reduces operating costs.

We aim to cover every requirement and, in addition to standard versions, also offer *cost-effective customised solutions.*



** Companies are responsible for ensuring that statutory workplace exposure limits in accordance with TRGS 611, TRGS 900, TRGS 910, etc. are complied with in order to minimise risks to employees.*

Precoat unit

A precoat unit coats the filter elements with a fine powder, known as a filter aid. This protective layer prevents sticky, oily or very fine particles from clogging or damaging the filter media.

ABSAUGWERK uses health-safe limestone powder, which is particularly effective. Precise dosing is crucial for optimal filter performance. This is monitored via level sensors and an integrated weighing system. As a result, the system remains reliably free from blockages or build-up.

Reliable system operation

Precise dosing

Dust-free filling

Contact switch on the system cover

Monitoring of dosing

No bridging & clogging



The precoat unit is also available in a premium version with an integrated scale and side extraction hoods, which directly capture rising precoat material during the filling of the system.

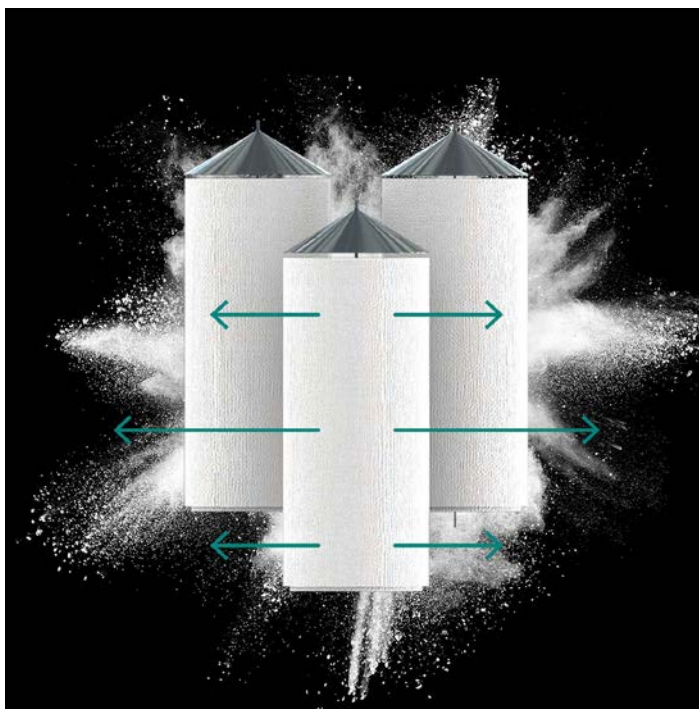

Automatic filter cleaning

The precoat agent, together with dust and fume particles, is removed from the filters by automatic jet pulse cleaning and conveyed into the extraction system's discharge container.

The short, powerful air pulses keep the filters permanently clean and their performance consistently high. This ensures safe and efficient operation while significantly reducing maintenance requirements.

real. sustainable.

SUSTAINABLE EXTRACTION SOLUTIONS

With their high separation efficiency, our dedusters are ideally suited for *recirculating air operation**, even in processes involving carcinogenic substances. A frequency inverter adjusts the extraction performance to actual demand, saving energy. From the very beginning of development, we focus on minimal flow resistance and efficient airflow design. The result: high-performance systems with very low energy consumption and an exceptionally durable, sustainable design. In this way, our dedusters make an important contribution to resource-efficient and energy-efficient production.

RESPONSIBILITY WITHIN THE COMPANY

All of our entrepreneurial activities are based on ecological, social and economic responsibility. Clean air in production halls protects the health of employees, helps prevent illness and makes workplaces safer. At the same time, machinery, tools and workpieces are protected, significantly extending their service life and increasing the economic efficiency of the entire operation.



** The cleaned air is so clean that it can be returned directly to the working environment. An integrated cross-flow heat exchanger uses the heat of the exhaust air for energy recovery, further reducing heating energy consumption.*

Your benefits

High-quality & durable

Low energy & operating costs

Low maintenance & personnel-friendly

Cleanable permanent filters

Flexible system components

Winter/summer mode (opt.)

Frequency inverter (opt.)

Cross-flow heat exchanger (opt.)

Primary explosion protection

Ex-Protection

In many industrial processes, flammable or explosive substances such as gases, vapours, mists or dusts are generated. When they come into contact with oxygen and an ignition source, an explosive atmosphere can quickly form, with devastating consequences for people, machines and operations.

ABSAUGWERK extraction systems are designed to proactively prevent the formation of explosive atmospheres. Thanks to their high separation efficiency, constant extraction performance, optimal airflow and ATEX-compliant components, they meet the requirements of **primary explosion protection**. At the same time, the specifications of secondary explosion protection are integrated into the system concept. This enables ATEX systems from ABSAUGWERK to be manufactured up to 50% more cost-effectively while sustainably reducing operating and maintenance costs.

Optionally, tertiary explosion protection measures can also be implemented as a supplement.



Legal requirements

Within the European Union, the ATEX Directives govern all requirements and specific aspects of explosion protection. They distinguish between manufacturers and operators, and compliance by both parties is essential to ensure long-term safety and occupational health protection. When designing our extraction systems, we take all relevant parameters into account, assess them in accordance with legal requirements and manufacture ATEX-compliant systems precisely tailored to the respective application.

EC DIRECTIVE	RESPONSIBILITY
2014/34/EU (ATEX 114)	Manufacturer
1999/92/EG (ATEX 137)	Operator

Your benefits

Savings of up to 50%

Low operating & follow-up costs

Maximum extraction performance

Maximum separation efficiency

Safe operation

Highest quality standards

Suitable for indoor installation



Our ATEX systems
meet the requirements
of primary explosion
protection!

Through various **ATEX measures** and an innovative design, we ensure the safe operation of our systems:

- Air velocity in pipe system ≥ 20 m/s
- Secured airflow monitoring
- ATEX-compliant motor or H14 filter upstream of the fan
- Ignition-source-free and conductive design
- Prevention of hazardous zones during operation
- Electrical components in ATEX design
- Control cabinet located outside the system
- Spark detection
- Automatic extinguishing systems in accordance with DIN/EN: water, powder, CO₂
- Automatic system shutdown
- Coated impellers
- ATEX-compliant compressed air filter cleaning
- ATEX components (*sensors, discharge systems, etc.*)



Fire protection

An often underestimated risk is not only health-hazardous dust, but also highly combustible dust. Especially when processing aluminium, magnesium, plastics or organic materials such as flour, dust deposits can form in pipe system or filters. If these come into contact with sparks, friction or electrostatic discharge, they can easily ignite.

ABSAUGWERK extraction systems minimise this risk through intelligent airflow design, spark pre-separators and high-quality filter media that prevent ignition sources. Optionally integrated fire protection systems and temperature sensors detect critical conditions at an early stage. This effectively reduces the risk of smouldering, fires or explosions.



Legal requirements

RESPONSIBILITIES OF OPERATORS & MANUFACTURERS

As part of a risk assessment (*suitability of the machines for the intended process*) and the preparation of an explosion protection document, the operator is required to assess whether there is a potential risk of fires or explosions.

The operator is required, as part of a risk assessment (assessment of the suitability of the machines for the intended process) and the preparation of an explosion protection document, to evaluate whether there is a potential risk of fires or explosions.

The manufacturer takes this information into account when defining an appropriate protection concept for the machine tool and aligns the operating and maintenance instructions accordingly.



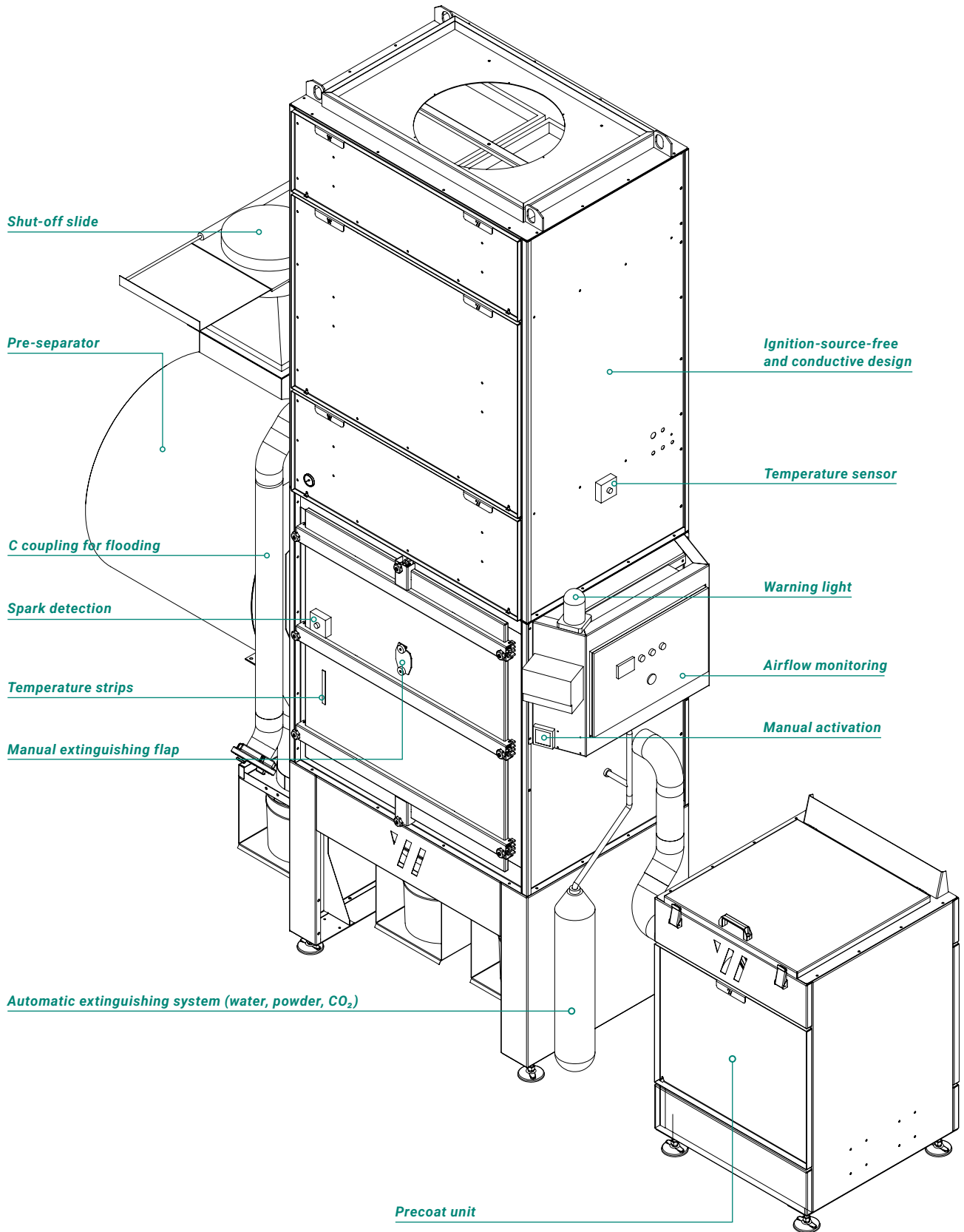

Fire protection components

Noise protection

Noise is one of the most common health risks in the workplace. Continuous exposure can lead to hearing damage, stress and impaired concentration. That is why our extraction systems are designed to operate particularly quietly and can be equipped with additional noise protection components – ensuring that noise exposure remains reliably below statutory limit values.

LIMIT VALUES & MEASURES

A daily noise exposure level LEX,8h **of 80 dB(A)** or a peak sound pressure level LpCpeak **of 135 dB(C)** requires:

- Information for employees
(when the action value is reached)
- Provision of hearing protection
(when the action value is exceeded)
- Offer of occupational medical health surveillance
(when the action value is exceeded)

A daily noise exposure level LEX,8h **of 85 dB(A)** or a peak sound pressure level LpCpeak **of 137 dB(C)** requires:

- Mandatory use of hearing protection
(when the action value is reached)
- Initiation of occupational medical health surveillance
(mandatory surveillance when the action value is reached)
- Identification and marking of noise areas
(when the action value is exceeded)
- Implementation of a noise reduction programme
(when the action value is exceeded)



Legal requirements

Workplace Ordinance
ArbStättV

Noise and Vibration Occupational Safety Ordinance
LärmVibrationsArbSchV

Technical Rules for the Noise and
Vibration Occupational Safety Ordinance
TRLV Noise

Your benefits

Optimised flow geometry

Smooth-running compressors

Maximum extraction performance

Low energy consumption

Noise exposure below 80 dB(A)



We offer a range of specialised **noise protection components** that can be precisely adapted to the process, room size and system performance, including:

- Baffle silencers
- Duct silencers
- Machine enclosures
- Noise protection cabins

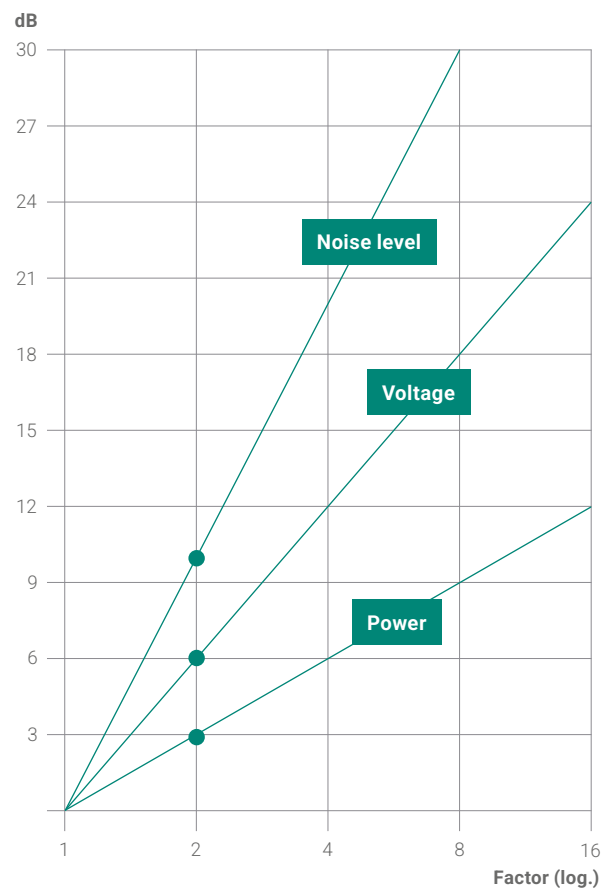

An increase in the noise level of just 3 dB already means a doubling of the sound power and is perceived as significantly louder.

+3 dB = double sound power

+6 dB = double sound pressure

+10 dB = double perceived loudness

Technical Data

7 different size variants
15 power levels



P/S Series 2000–3000

DEDUSTER SERIES		P/S 2000	P/S 2000	P/S 2000	P/S 2000	P/S 3000	P/S 3000	P/S 3000	P/S 3000
Motor power	kW	1,1	2,2	3	4	4	5,5	7,5	11
Max. fan power	m³/h	2,400	3,500	4,500	6,000	6,000	7,000	8,500	15,000
Width (b)	mm	850	850	850	850	1,250	1,250	1,250	1,250
Depth (t)	mm	850	850	850	850	850	850	850	850
Height A (drawer)	mm	860	860	860	1,410	–	–	–	–
Height B (drawer)	mm	2,240	2,240	2,240	2,915	–	–	–	–
Height C (drawer + H14)	mm	2,540	2,540	2,540	3,240	–	–	–	–
Height A (50L bin)	mm	1,165	1,165	1,165	1,715	1,850	1,850	1,850	1,850
Height B (50L bin)	mm	2,560	2,560	2,560	3,220	3,575	3,575	3,575	3,725
Height C (50L bin + H14)	mm	2,895	2,895	2,895	3,535	3,925	3,925	3,925	4,075
Height A (100L bin)	mm	–	–	–	–	2,050	2,050	2,050	2,050
Height B (100L bin)	mm	–	–	–	–	3,775	3,775	3,775	3,925
Height C (100L bin + H14)	mm	–	–	–	–	4,125	4,125	4,125	4,125
Height A (16L bucket)	mm	1,320	1,320	1,320	1,870	1,775	1,775	1,775	1,775
Height B (16L bucket)	mm	2,715	2,715	2,715	3,375	3,500	3,500	3,500	3,650
Height C (16L bucket + H14)	mm	3,050	3,050	3,050	3,690	3,850	3,850	3,850	4,000
Height A (30L bucket)	mm	1,470	1,470	1,470	2,020	1,925	1,925	1,925	1,925
Height B (30L bucket)	mm	2,865	2,865	2,865	3,525	3,650	3,650	3,650	3,800
Height C (30L bucket + H14)	mm	3,200	3,200	3,200	3,840	4,000	4,000	4,000	4,150

Status June 2026 | Subject to change

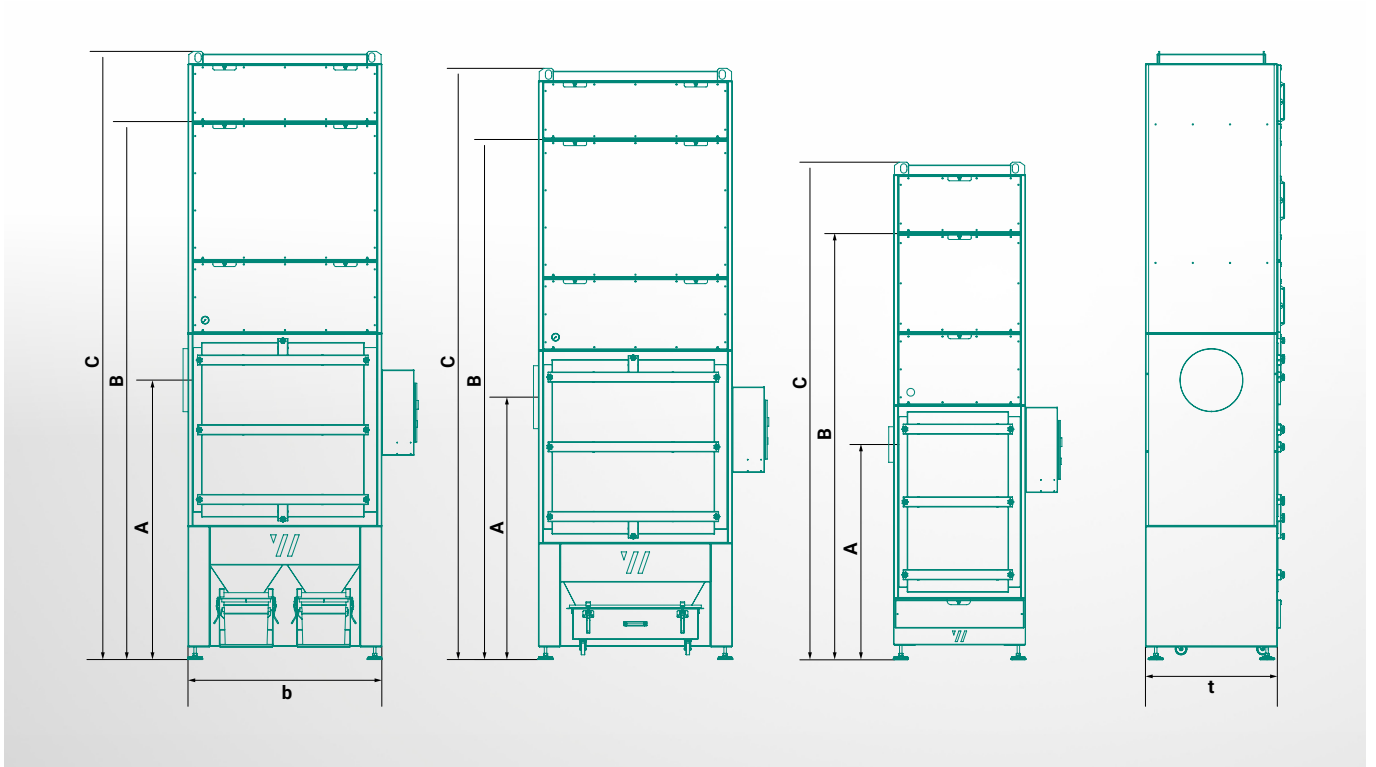

P/S Series 4000–8000

DEDUSTER SERIES		P/S 4000	P/S 4000	P/S 4000	P/S 5000	P/S 6000	P/S 7000	P/S 8000
Motor power	kW	15	18,5	22	22	30	37	45
Max. fan power	m³/h	18,000	23,000	23,000	23,000	30,500	32,500	36,500
Width (b)	mm	1,250	1,250	1,250	1,840	1,840	2,260	2,260
Depth (t)	mm	1,350	1,350	1,350	1,420	1,840	1,840	2,260
Height A (drawer)	mm	–	–	–	–	–	–	–
Height B (drawer)	mm	–	–	–	–	–	–	–
Height C (drawer + H14)	mm	–	–	–	–	–	–	–
Height A (50L bin)	mm	1,800	1,800	1,800	–	–	–	–
Height B (50L bin)	mm	3,800	4,050	4,050	–	–	–	–
Height C (50L bin + H14)	mm	4,050	4,400	4,400	–	–	–	–
Height A (100L bin)	mm	2,000	2,000	2,180	2,350	2,350	2,350	2,750
Height B (100L bin)	mm	4,000	4,250	4,250	4,575	4,575	4,575	4,575
Height C (100L bin + H14)	mm	4,250	4,600	4,600	5,175	5,175	5,175	5,175
Height A (16L bucket)	mm	2,000	2,000	2,000	2,180	2,350	2,350	2,750
Height B (16L bucket)	mm	4,000	4,250	4,250	4,575	4,575	4,575	4,575
Height C (16L bucket + H14)	mm	4,250	4,600	4,600	5,175	5,175	5,175	5,175
Height A (30L bucket)	mm	2,150	2,150	2,150	2,330	2,500	2,500	2,900
Height B (30L bucket)	mm	4,150	4,400	4,400	4,725	4,725	4,725	4,725
Height C (30L bucket + H14)	mm	4,400	4,750	5,325	5,325	5,325	5,325	5,325

Status June 2026 | Subject to change



Reference

ATEX dedusters and grinding cabins for indoor installation at Ohm & Häner

Ohm & Häner Metallwerk GmbH & Co. KG, based in South Westphalia, is one of the leading companies in the foundry industry. With around 650 employees, the family-owned company manufactures high-quality aluminium cast components and supplies customers worldwide with precisely machined raw castings, sand castings and permanent mould castings. During decoring, fettling and grinding processes, hazardous and potentially explosive dusts are generated. For this purpose, Ohm & Häner was looking for a high-performance extraction solution for safe indoor installation directly at the points of origin.

»What we particularly appreciated was how little space the system requires. Indoor installation saves energy and ensures a uniform appearance.«

*Dr. Georg Wilhelm Dieckhues,
Managing Director Ohm & Häner Metallwerk GmbH & Co. KG*



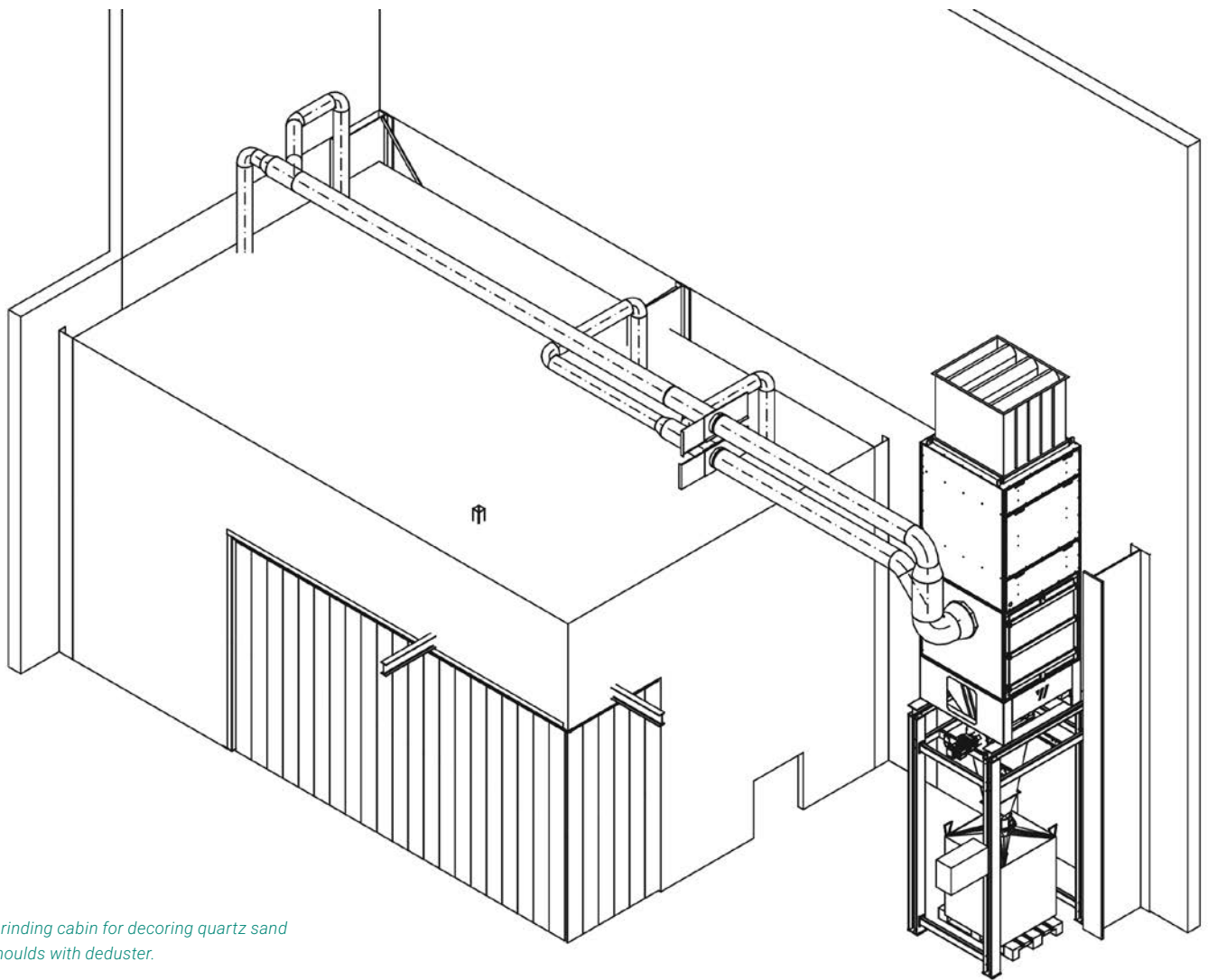

Grinding cabin for decoring quartz sand moulds with deduster.

CHALLENGE

For two grinding cabins, an extraction solution was required for quartz dust and explosive aluminium dust. The systems needed to be installed indoors in a space-saving manner, operated energy-efficiently and equipped with automatic discharge.

SOLUTION

For the new work area, ABSAUGWERK installed two sound-insulated grinding cabins with side hoods and worktables for precise dust capture. One cabin is used for decoring quartz sand moulds, while the other is used for grinding aluminium cast components. An ATEX deduster captures the aluminium dust, while a second deduster reliably filters quartz dust. The multi-stage filter system with HEPA H14 technology and automatic rotary valves ensures reliable air cleaning and safe material disposal.

Filter performance, fill levels and filter cleaning are automatically monitored via SIEMENS LOGO! 8. As a result, the system operates efficiently, safely and with low maintenance requirements, fully meeting the demands of modern ATEX dry extraction.



Watch the Ohm & Häner reference video at absaugwerk.de/en/ohm-haener-metallwerk

MEDIA

- Quartz dust, aluminium dust (explosive & combustible)

PROCESSES

- Decoring, grinding, fettling

PERFORMANCE

- Motor power: 11 kW + 30 kW
- Max. airflow: 15.000 m³/h + 31.000 m³/h

SERVICE

Personal consultation, technical design, pipe system planning, production, installation, pipe system, commissioning, maintenance and after-sales support



»ABSAUGWERK was the only manufacturer able to truly meet our requirements.«

*Dr. Georg Wilhelm Dieckhues,
Managing Director Ohm & Häner Metallwerk GmbH & Co. KG*



Fig. 1



Fig. 2



Fig. 3



Fig. 4

Fig. 1
2x P Series 4000, 22 kW
Side cyclone pre-separator

Process: Grinding
Material: Aluminium (ATEX)
Medium: Dry dust
Capture: 5x extraction tables
Discharge: Dust collection buckets

Fig. 2
P Series 3000, 11 kW
Side cyclone pre-separator

Process: Deburring
Material: Aluminium, stainless steel, carbon steel (ATEX)
Medium: Dry dust
Capture: Direct connection
Discharge: Dust collection buckets

Fig. 3
S Series 4000, 7,5 kW
Side cyclone pre-separator

Process: Grinding, polishing
Material: Lint, polishing compound, glas (ATEX)
Medium: Dry dust
Capture: 2x Extraction cabins
Discharge: Dust collection buckets

Fig. 4
R Series 2000, 4 kW
Side cyclone pre-separator

Process: Grinding
Material: Aluminium (ATEX)
Medium: Dry dust
Capture: 12x Hopper provided by customer
Discharge: Dust collection buckets

360° all-round service

Consulting

Free needs analysis and individual quotation by our sales team.

Marketing

Support in marketing through videos as well as customised design and branding.

Project planning

Personal support including an on-site inspection and the specification of technical parameters.

Training

Introduction to system components and performance of minor service and maintenance tasks.

We keep your WERK running!

Installation

Delivery and installation of the extraction system, including installation of the pipe system.

After-Sales

The full range: Spare and wear parts, cleaning, training, repairs and retrofitting.

Commissioning

Mechanical and electrical system briefing covering functionality, safety and control.

Maintenance

Comprehensive service for third-party and in-house systems to ensure smooth operation.

Your benefits

Everything from a single source

In-house & third-party maintenance

Free process analysis

Personal on-site appointment

Smooth & safe operation

Avoidance of downtime & follow-up costs

Worldwide support

Remote diagnostics & maintenance

Maintenance

Unplanned system downtime can not only cause high costs, but also put employee safety at risk. To ensure that your extraction systems operate efficiently and reliably over the long term, ABSAUGWERK offers a comprehensive maintenance service. Regular inspections allow technical deviations to be identified at an early stage, before they develop into costly or safety-critical issues. Our many years of expertise and a well-structured service organisation ensure short response times and rapid fault resolution.

REMOTE MAINTENANCE – WORLD WIDE WERK

In automated production environments, reliability is essential. Our remote maintenance systems monitor system parameters in real time and automatically notify us of critical deviations. This enables our service technicians to respond immediately, regardless of location. Intelligent monitoring, modern alarm functions and secure VPN encryption provide fast support, protect your data and offer maximum flexibility at the same time.

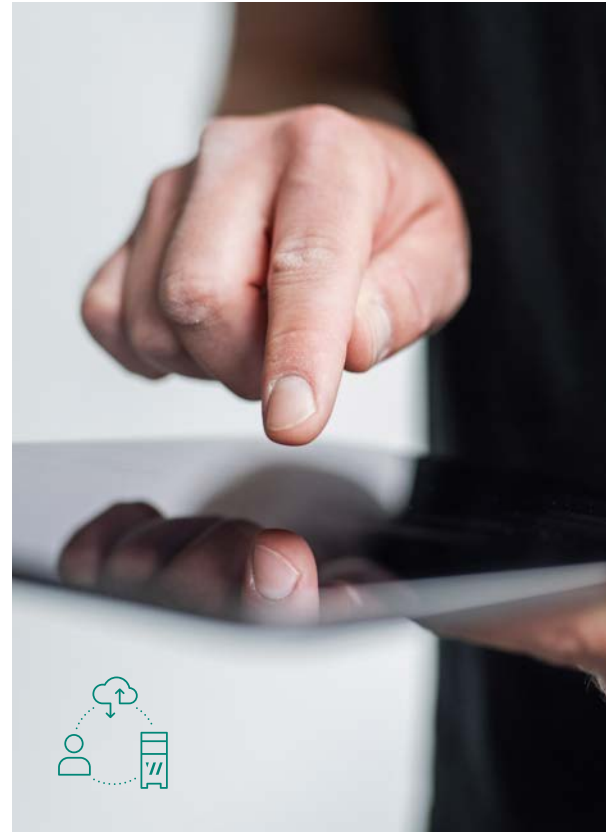

We service both in-house and third-party systems.
You only need one appointment and one site visit!

Request your non-binding maintenance offer:
sales@absaugwerk.de





Quality from Neu-Ulm!

Our WERKER are professionals in their field and see themselves as part of the overall WERK. With more than 200 years of combined experience in extraction technology, we create durable and robust extraction systems handcrafted and »MADE IN NEU-ULM«! Every system undergoes strict quality and safety testing before it leaves our WERK.

We continuously invest in training and technology to keep moving the market forward. Our innovative strength has been recognised with the BSFZ seal – a mark of research-based development and publicly funded innovation. Our goal: better working conditions, sustainable environmental protection and your success with perfect workpieces.

We configure extraction systems individually and provide premium service directly from our WERK. That's what makes our solutions **real. better.**



Every WERKER considers themselves part of a responsible society and a healthy environment.



Learn what matters in extraction technology!

Effective extraction is essential for safe and healthy working environments. We inform you about relevant workplace exposure limits and legal requirements, and show you which solutions best suit your processes.

You will also get to know the various components of our systems: we explain what matters in system design, planning and maintenance, and provide practical tips for minor service tasks.

For our OEM and distribution partners, we offer customised training programmes, either directly at your site or at our WERK in Neu-Ulm.

Feel free to contact us:

info@absaugwerk.de | +49 731 141 108-0

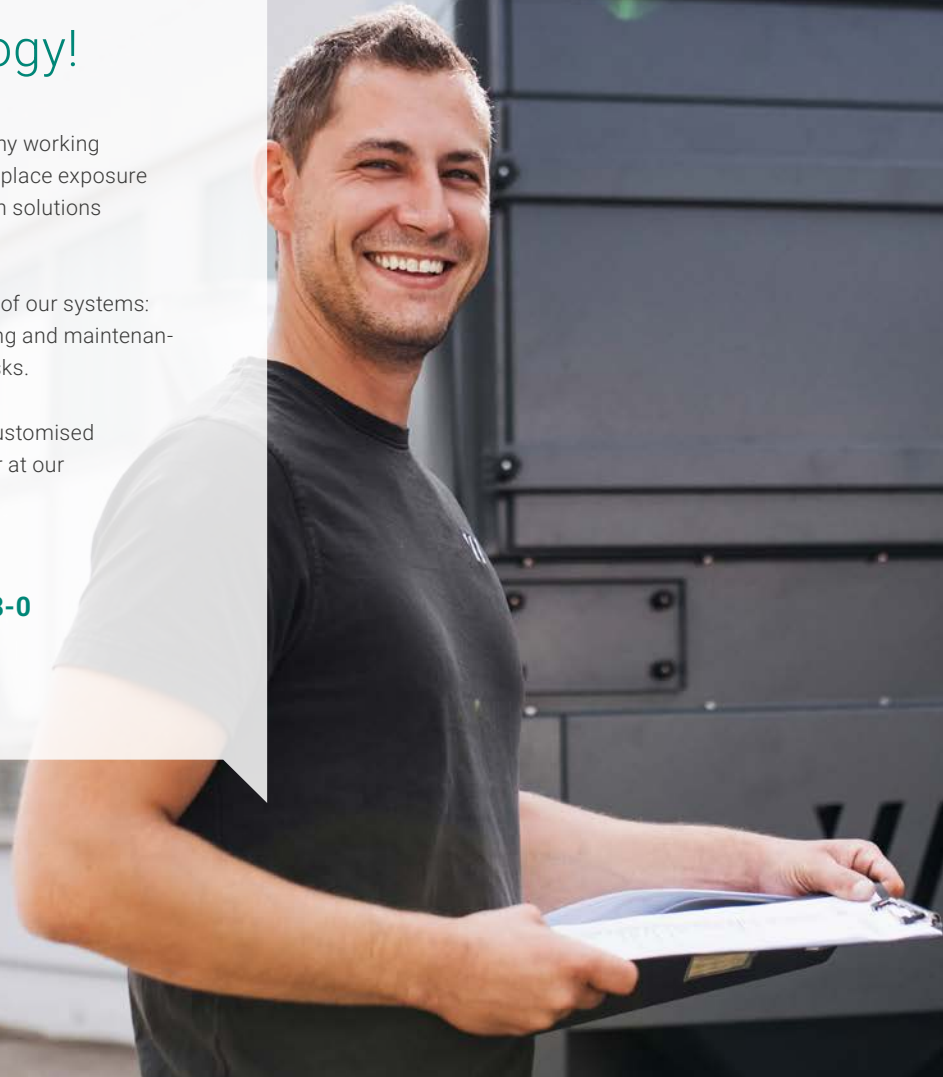

real. personal.

ABSAUGWERK stands for lived values that go far beyond technology. Our employees share not only expertise, but also common values of teamwork, responsibility and trust. This culture forms the foundation of our success and our »feel-good philosophy«.

Within our network, we also focus on genuine partnerships: open, respectful and on equal footing. We believe in long-term relationships built on reliability and mutual appreciation, because only together can something be created that truly lasts.

ABSAUGWERK GmbH
Messerschmittstr. 22
DE-89231 Neu-Ulm

+49 731 141 108-0
info@absaugwerk.de
www.absaugwerk.de

Follow us on social media:



[@ABSAUGWERK GmbH](https://www.instagram.com/absaugwerk)



Project process

5 steps to your perfect extraction solution!

- **01** **Process analysis**

In the first step, your work processes are analysed, pollutant sources are identified and existing extraction systems are reviewed in order to determine the exact extraction requirements.
- **02** **Personal on-site visit**

Our experts assess the local conditions directly at your site and take precise measurements to plan the ideal solution for your operation.
- **03** **Individual quotation**

Based on the analysis and technical drawings, you will receive a customised quotation within a short time, offering the most economical solution for your needs.
- **04** **Production**

Once the technical drawings have been approved and the order placed, we immediately begin procurement, manufacturing and scheduling for installation.
- **05** **Installation**

Our installers set up the complete extraction system, including pipe system, and support you during commissioning. Performance and functionality are carefully tested and documented – ensuring a smooth start-up.



absaugwerk.de

real. better.