



ABSAUGWERK

ABSAUGWERK GmbH

Company Presentation

From dedusters, fume filters, oil mist separators and wet separators to complete hall extraction systems:

Optimal solutions for almost every process and every material

Together,
over 200 years
of **experience**
in extraction
technology

real. better.

ABSAUGWERK stands for high-quality extraction solutions for the manufacturing industry.

Our strength lies in the in-house development and production of customized extraction systems to protect people, machines and the environment.



[This is ABSAUGWERK | real. better.](#)



MICHAEL WERZ | Managing Director

SMOOTH.
RELIABLE.
SAFE.



Service & Sales

We support our customers throughout the entire service chain, from the initial consultation through installation and beyond. This ensures that their systems always function optimally.

Quality from Neu-Ulm

Every employee at ABSAUGWERK is an absolute professional in their field. This enables us to guarantee high-quality systems and services. We have great respect for our customers' end products and are proud to contribute to a perfect workpiece with our systems.

We are proud of the quality of our handcrafted products »Made in Germany« and take full responsibility for their performance and efficiency.



MADE IN GERMANY



Deeply rooted in the industry

Together, our team has 200 years of experience in extraction technology. Every one of our employees sees themselves as part of the overall WERK.

As a young and growing company, we strive to drive innovation and foster a modern corporate culture.

YOUNG.
DYNAMIC.
WILD.



Partnership within the WERK

ABSAUGWERK reflects the personal values of its employees and combines them with shared ideas of teamwork, corporate management and goals. This culture forms the foundation of our success and our “feel-good philosophy”.

The same applies to our network. We are not afraid of commitment! We continuously maintain our partnerships on a personal level; we sell to and buy from people. Mutual respect and reliability are indispensable to us.

RESPECTFUL.
PROFESSIONAL.
PERSONAL.



Flexible for every application



YOUR INDUSTRY SECTOR

Mechanical engineering, food, chemicals, automotive and many more.



YOUR PROCESS

Grinding, polishing, welding, sawing, cutting and many more.



YOUR MEDIA

Dusts, chips, fumes, oils, vapours, aerosols and many more.

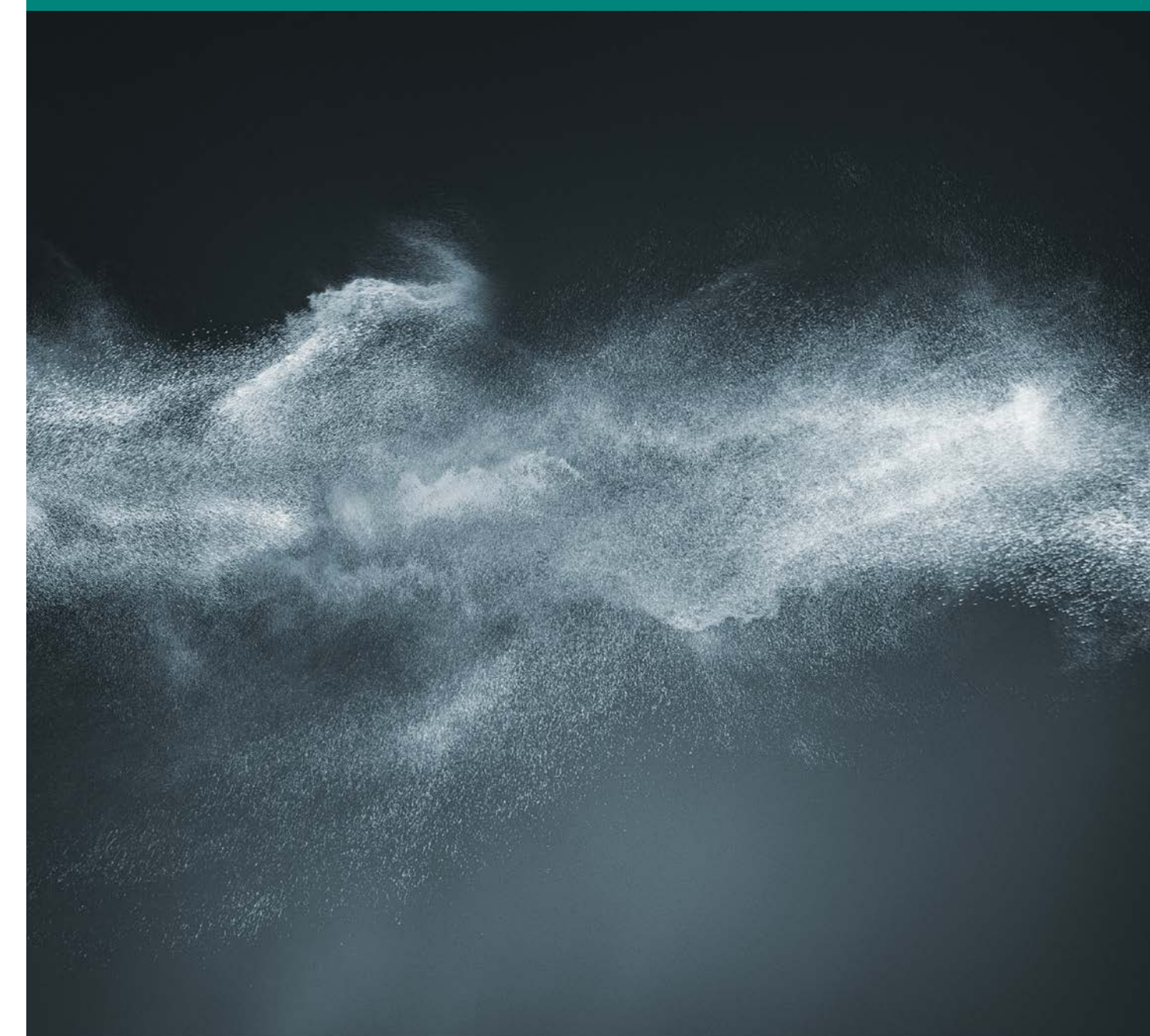

Versatile Extraction Solutions

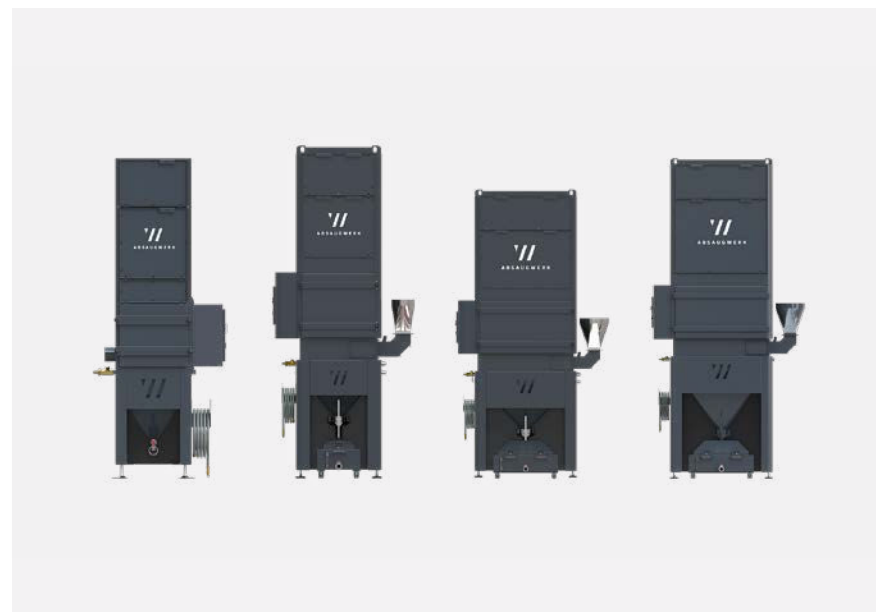

Wet separator

B series 



Deduster

P/S series



Fume filter

R series | **Smart X**



Oil mist separator

O/E series | **Compact**

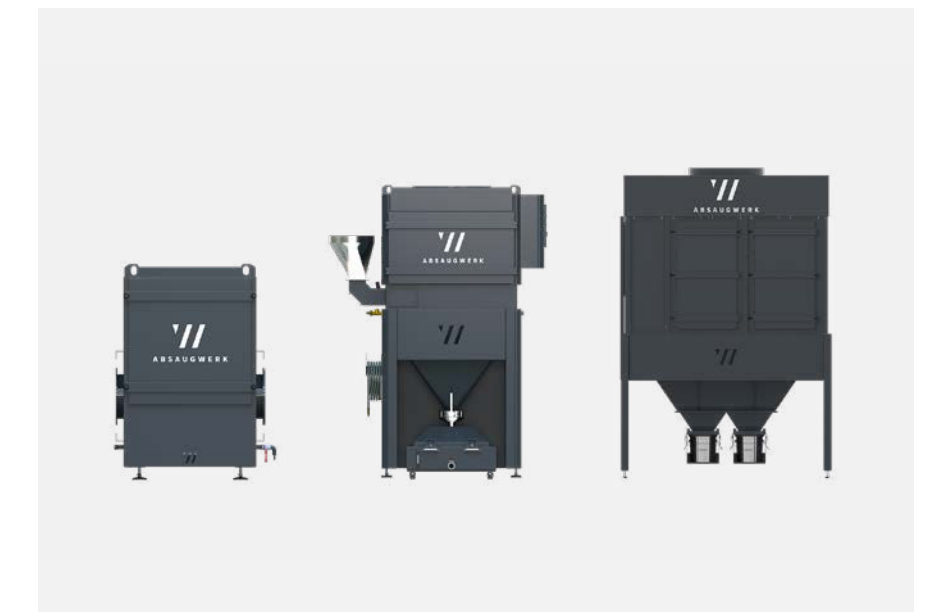

Filter units

S/P/R O/E B series



Filter tower

FlowX



Hall extraction systems

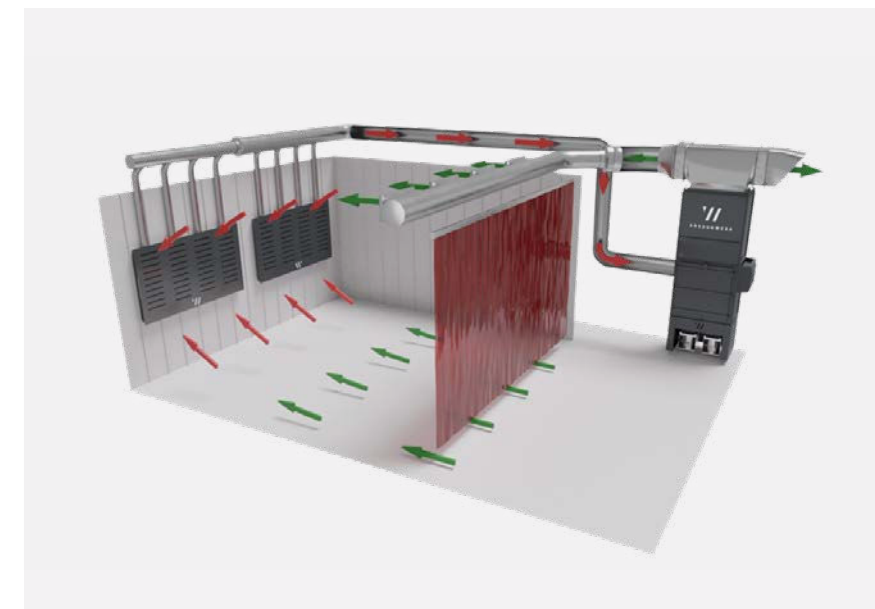

Extraction cabins



Machine extraction systems

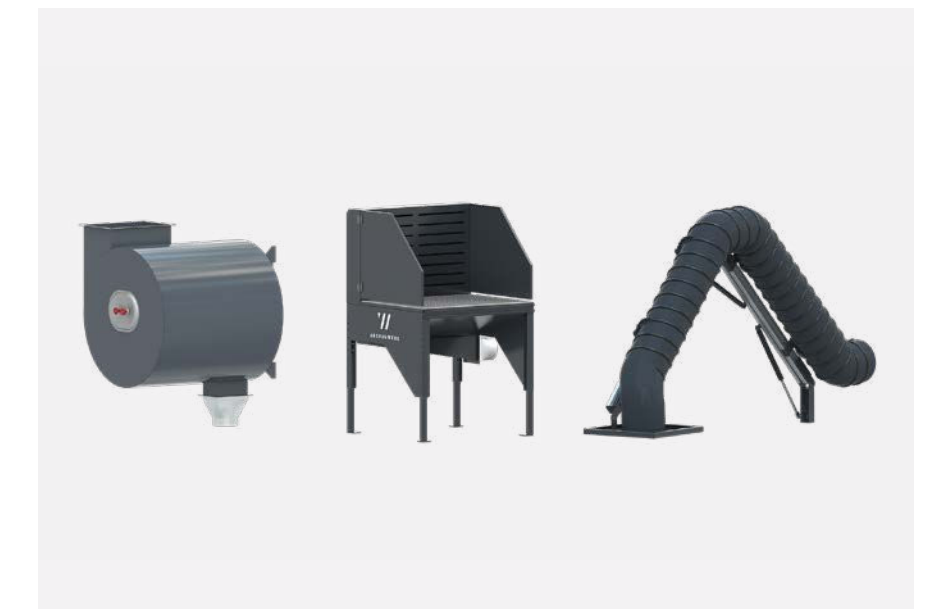

Accessories & options

Standard Solutions ✗

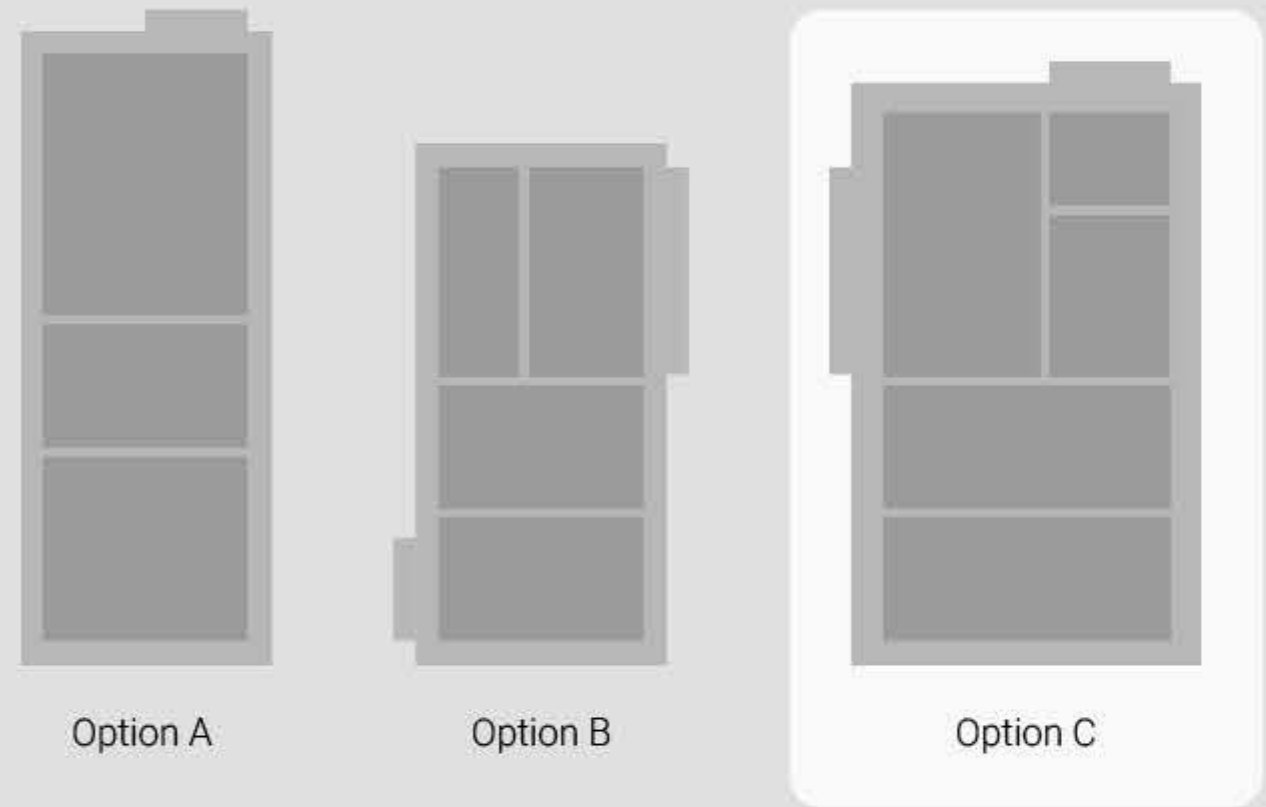

The ABSAUGWERK Principle: ✓ Customized Solutions

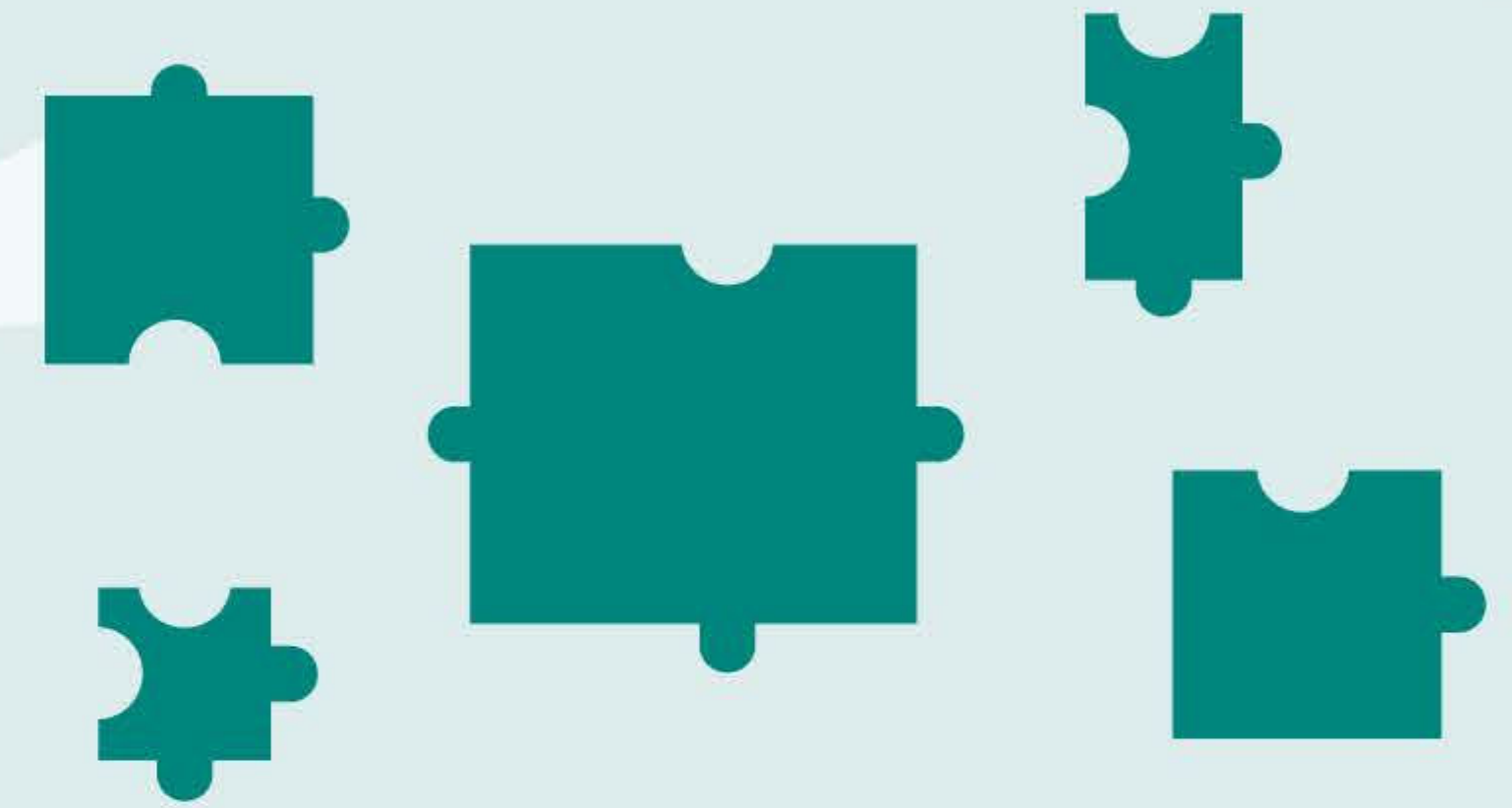
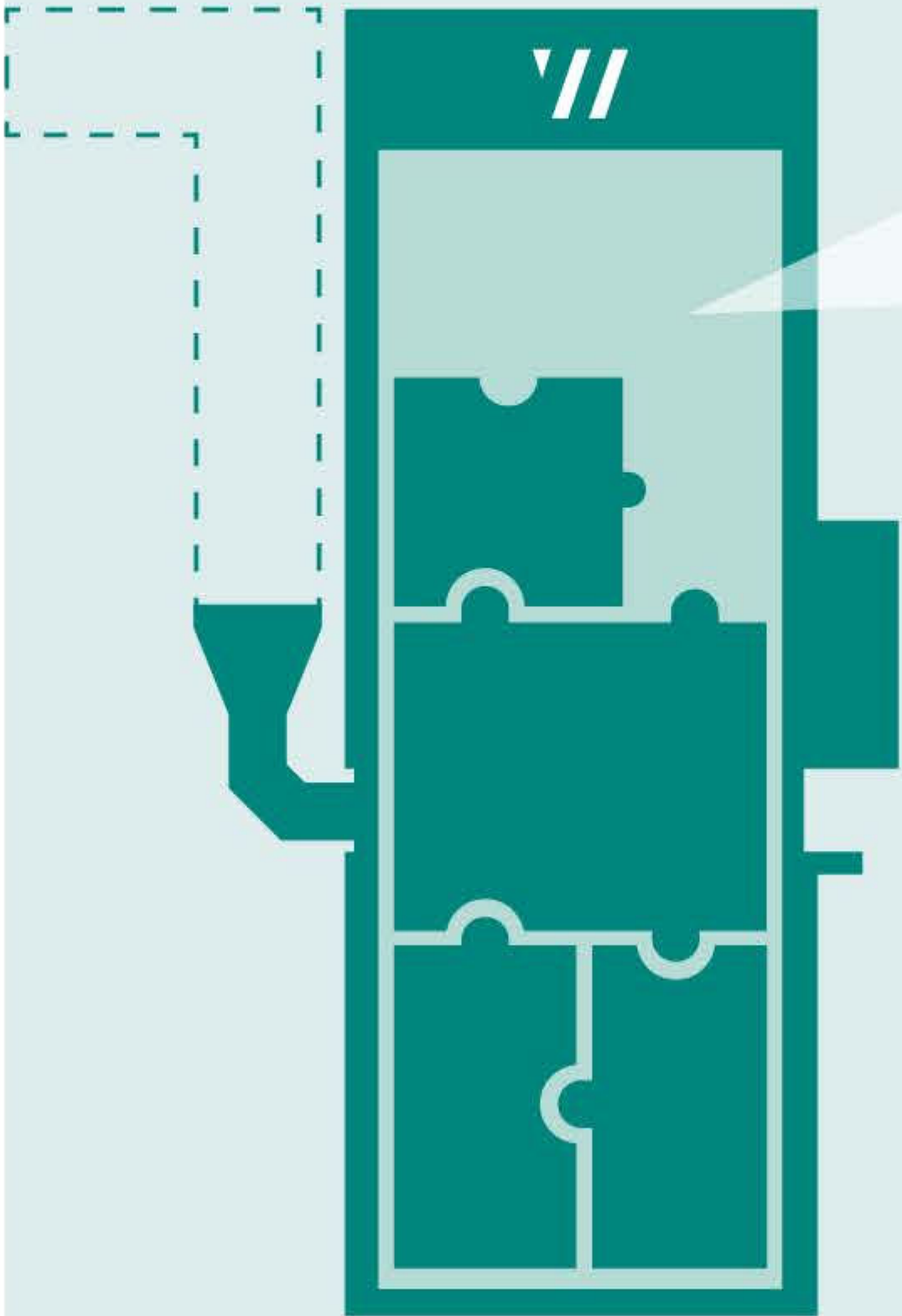
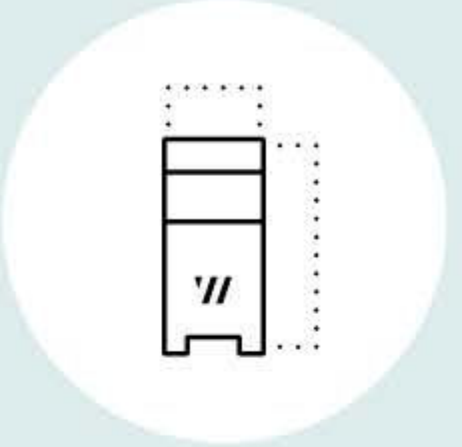

We develop and manufacture customized extraction systems tailored individually to our customers.

For maximum performance and energy efficiency.

This makes our systems real. better.



Everything from a single source & directly from our WERK.

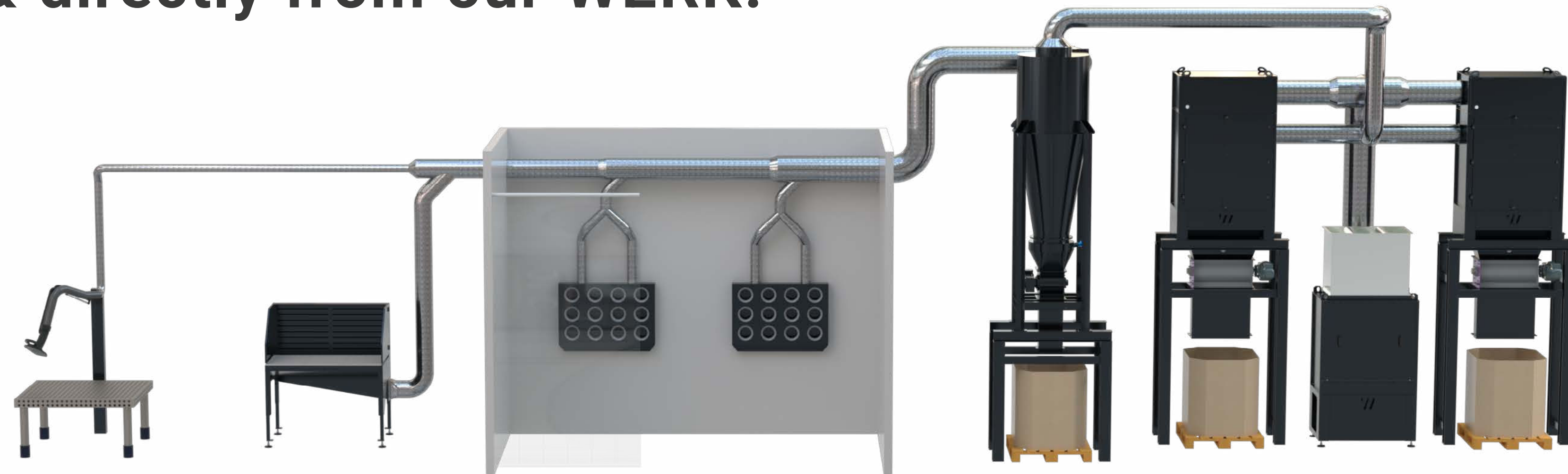

Explosion protection
(ATEX)



Fire protection



Noise protection

Capture



+ Pipe system



+ Extraction system



+ Custom solution



World Wide WERK

Production processes must function smoothly and efficiently to ensure maximum profitability.

Remote maintenance systems monitor machine condition, filter saturation, maintenance intervals, operating hours, sensor data and other parameters in real time. If required, an automatic alarm notification is triggered. This allows malfunctions to be resolved at an early stage and prevents consequential damage and machine downtime.

**WORLDWIDE
AVAILABILITY.**



High-performance & future-proof

As a manufacturing company serving a wide range of industrial sectors, we bear a special responsibility for the quality of our products and processes, as well as for the preservation of our environment and resources.

The flexible components of our systems enable customized extraction systems. Unlike standard systems, these consume only the amount of energy, air and water that is actually required. In this way, we make a positive contribution to your energy balance.

DURABLE.
FLEXIBLE.
EFFICIENT.

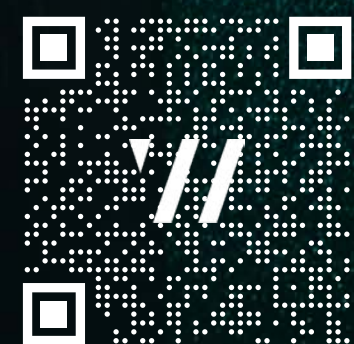

Deduster P/S series | Energy-saving and sustainable.

real. better.

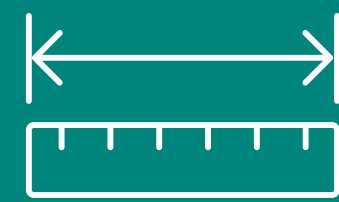

Customized
Extraction
Solutions



For every
industry & every
application

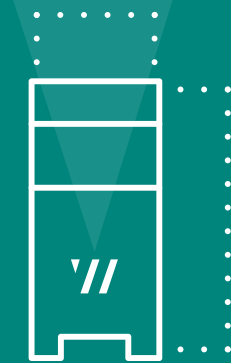

Numerous
variants
& options



360° Service:
From consulting to
after-sales service!



Quality
made in
Germany

reliable. honest. personal.



ABSAUGWERK.de

ABSAUGWERK GMBH

Messerschmittstr. 22

DE-89231 Neu-Ulm

+49 731 141108-0

info@ABSAUGWERK.de