



**A B S A U G W E R K**

**WET SEPARATOR**  
**B SERIES**



## The WERK

As a manufacturer of industrial extraction technology, we strive for a clean and healthy working environment. Our strength lies in the in-house development and production of customised extraction systems designed to protect employees, machines and workpieces.

From industrial dedusters and oil mist separators to complete hall extraction systems, we offer a comprehensive portfolio of solutions. We combine capture elements, extraction units and pipe systems into an integrated overall system that sets new standards in terms of energy efficiency and performance. In the field of explosion and fire protection, we are one of the few providers that fully meet all legal requirements and are able to ensure safe operation. With our many years of expertise, we develop special solutions for companies of all sizes and across all industries.

The production of our high-end systems takes place at our own WERK. Here, quality and precision are our top priorities. We support our customers throughout the entire service chain – from initial consultation through to installation and beyond. This ensures that their systems always operate at optimum performance.

We place particular emphasis on maintaining our NetzWERK. Honesty, trust and personal contact form the foundation for long-term and successful partnerships.

»People, as customers, partners or employees, are always at the heart of our company.«

*Michael Werz, Managing Director*

Introduction	<b>1</b>
←—————	
Wet separator	<b>3</b>
Applications & components	<b>7</b>
Functionality	<b>9</b>
The ABSAUGWERK Principle	<b>10</b>
Accessories & options	<b>11</b>
Sustainability	<b>16</b>
Explosion protection	<b>17</b>
Fire protection	<b>19</b>
Noise protection	<b>21</b>
Technical data	<b>23</b>
Reference	<b>25</b>
—————→	
All-round service	<b>27</b>
Quality	<b>29</b>
Training & partnership	<b>31</b>
Project process	<b>32</b>





## Working with flying sparks?

### PROBLEM

In industrial manufacturing processes, such as grinding, cutting, sawing, or milling, sparks, hot particles, and fine metal dust are generated. These seemingly harmless substances pose enormous risks: even small quantities of aluminum or magnesium dust can form an explosive atmosphere when combined with oxygen and an ignition source.

Dust explosions have been among the most dangerous yet often underestimated risks in industrial operations for years. Time and again, serious accidents occur because fine

metal or plastic dust is ignited by sparks or hot particles, sometimes causing significant damage to employees, machinery, and entire production lines.

In addition to the acute risk of fire and explosion, the resulting fine particulates also pose a serious health hazard. Materials such as aluminum, nickel, or chromium are respirable and can cause chronic respiratory diseases or even cancer.

Conventional dry filter systems often reach their limits due to the extreme heat genera-

ted or even become a source of danger themselves. At the same time, legal requirements for occupational safety and low-emission manufacturing processes are increasing. As a result, companies must find ways to reliably separate sparks, dusts, and aerosols – without the risk of filter materials igniting or wearing out prematurely.

# WET SEPARATOR

## B Series



### SOLUTION

The solution is wet separation: instead of guiding contaminated air through combustible filter media, dust and sparks are directly bound in water. Glowing particles are extinguished immediately, and fine particulates are reliably separated. ATEX-compliant wet separators from ABSAUGWERK are designed according to the principle of primary ATEX explosion protection, preventing the formation of an explosive atmosphere in the first place.

The Series B combines maximum extraction performance with minimal energy and water consumption, protecting not only employees and equipment but also valuable resources. With innovative flow technology, intelligent discharge systems, and individual configuration options, it becomes a holistic solution: maximum safety in accordance with ATEX standards, efficient separation of hazardous dusts, and more sustainable production.



### Performance:

2,350 – 22,000 m<sup>3</sup>/h\*

1.1 – 22 kW

*\* Systems connected in series have the potential to deliver virtually unlimited performance.*

## Your benefits

---

**High extraction power**

---

**Low water & power consumption**

---

**Patented flow technology**

---

**ATEX-compliant construction**

---

**Durable filter components**

---

**Easy cleaning & maintenance**

---

**Individual configuration & special solutions**

---

**Recirculating air for carcinogenic materials**

---

**Remote maintenance & remote access**

---

**Exclusive design**



The interior of the system is conveniently accessible via several inspection openings. This saves valuable time during cleaning and maintenance.



**The best  
in its class!**



Machining center

**- 2 dB(A)**

 approx. quieter



**+ 50%**  
more  
extraction power



**+ 25%**  
more  
filter area



**- 30%**  
less  
energy costs  
per year



**- 20%**  
less  
water use per year



Compared to conventional extraction systems.

# Application

During cutting, grinding, separating, or machining metals, sparks, hot particles, and fine dusts are generated that remain suspended in the air inside the production hall. In particular, aluminum, magnesium, or titanium dusts are highly flammable and can form an explosive atmosphere when combined with sparks. At the same time, the fine particles penetrate deep into the respiratory tract and pose a significant health risk.

## INDUSTRIES

Automotive, chemical industry, food industry, metal processing, pharmaceutical industry, etc.

## PROCESSES

- Polishing
- Grinding
- Cutting
- Separating
- Sawing, etc.

## MEDIA

Dust & chips  
*flammable, explosive,  
 free-flowing, powdery,  
 wet, oily, sticky*



## Filter:

- Stainless-steel mesh filters

## Discharge:

- Container
- Sludge container
- Pinch valve
- Ball valve
- Gate valve
- Continuous discharge
- Individual discharge

## Capture:

- Extraction arm
- Extraction table
- Extraction hood
- Pipe system
- Machine connection
- Room capture
- Individual capture

## Equipment:

- 11 power levels
- Integrated pre-separator
- Multiple filter stages for max. degree of separation
- Cleanable permanent filters
- IE3 to IE5 motors

# Components

The wet separators from ABSAUGWERK are precisely configured for each individual process. They bind sparks and dusts directly in water and clean the air using lamella and stainless steel knit filters. If required, optional HEPA H14 filters ensure maximum safety when handling carcinogenic dusts. Activated carbon filters are used to eliminate unpleasant gases and odors.

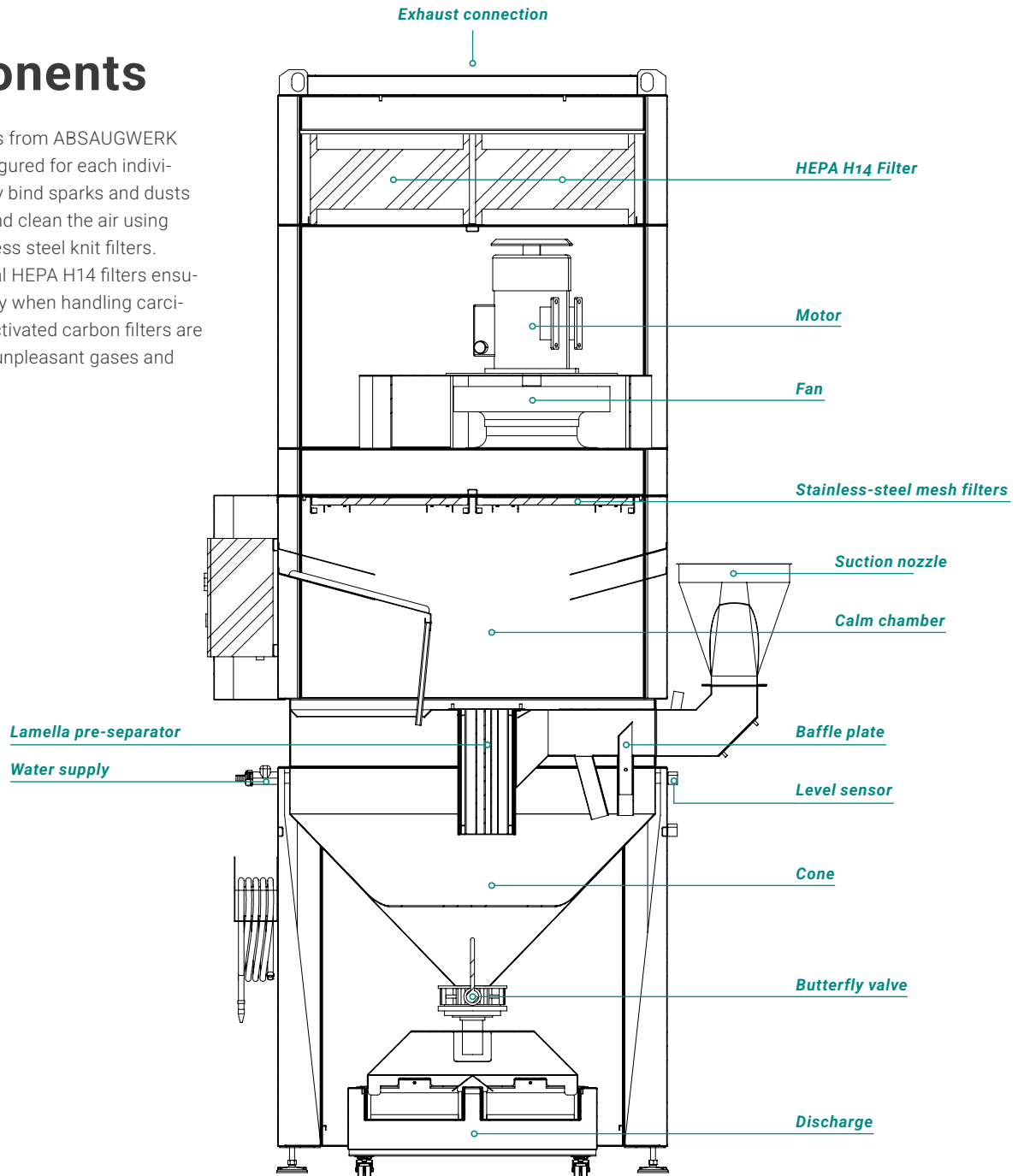

## Options:

- HEPA H14 filters for carcinogenic substances in recirculation air operation
- Activated carbon filter for gases and odors
- ATEX / fire protection execution
- Effective noise protection
- Versatile intelligent controls
- Individual system colour & branding

**ATEX-compliant  
construction**



**Market-leading  
energy efficiency**



# Functionality

The wet separators clean the air in several stages: A patented multi-chamber system combined with state-of-the-art filter technology reliably binds sparks and dust.

## 1. SUCTION

The contaminated air is extracted via a direct machine connection or another capture device.

## 2. DEFLECTION PLATE

Dust and chips are guided downward into the water via a deflection plate. 25% of the air flow is directed upward.

## 3. WATER WALL

Due to the negative pressure, water is drawn upward, forming a water wall that binds the remaining dust.

## 4. PRE-SEPARATOR

The air then flows through a lamella pre-separator. The special lamella geometry separates the air from the water again.

## 5. CONE

Substances bound in the water settle at the bottom of the cone. Rounded corners prevent deposits.

## 6. CALM CHAMBER

Residual water is separated from the air via baffle plates and guided back down into the cone.

## 7. FILTER STAGE 1

Remaining fine particles and residual moisture are separated using a stainless steel knit filter.

## 8. FAN

The fan with IE3 technology, optionally available with IE4 or IE5, operates extremely quietly, efficiently, and with high performance.

## 9. FILTER STAGE 2

For fine dusts, viruses, or carcinogenic stainless steel dusts, an additional HEPA H14 filter is used.

## 10. EXHAUST

The cleaned air is discharged outdoors or returned to the room in recirculating air operation, reducing heating and energy costs.

## 11. GATE VALVE

Sludge and water can be quickly drained via a large gate valve (Ø 100 mm).

## 12. DISCHARGE

The sludge can be easily disposed of via an individual discharge system.

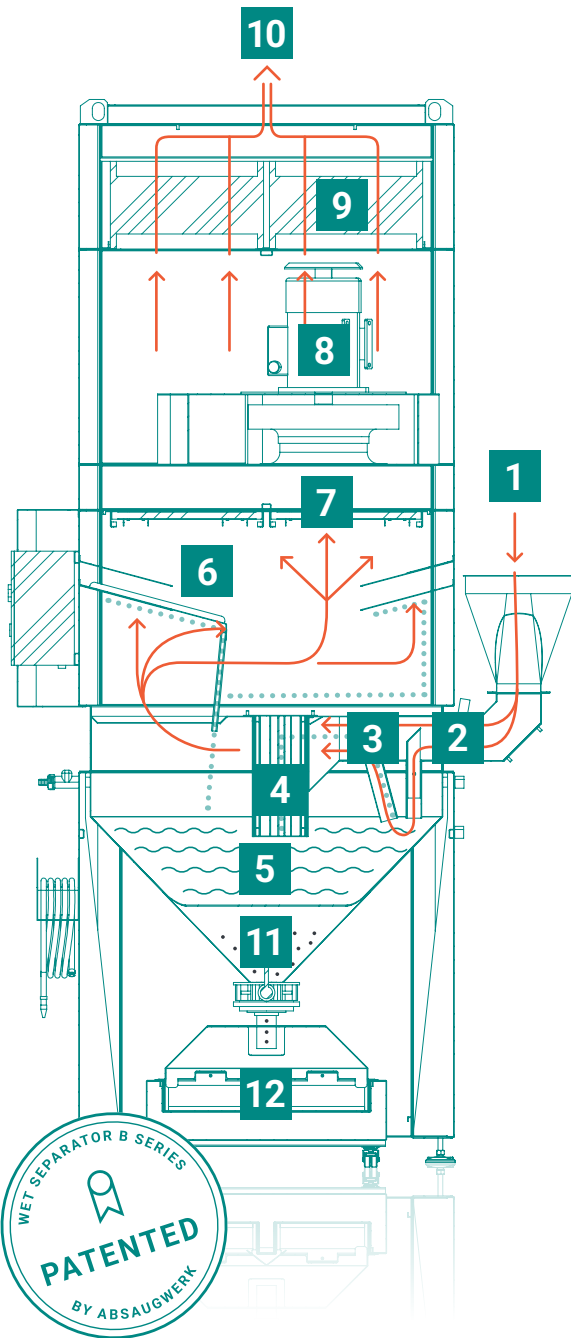

The wet separator of the B series features innovative flow technology with up to 50 % higher extraction performance and maximum separation efficiency, while simultaneously reducing energy and water consumption.

The stainless-steel mesh filters from ABSAUGWERK can be cleaned using a conventional high-pressure cleaner and are reusable.

# The ABSAUGWERK Principle

A high-performance and energy-efficient extraction system consists of several components that must work in perfect harmony. If elements such as capture systems or the pipe system reduce performance, this can not only impair functionality but also lead to deposits and dangerous fires. As every application is unique, we develop and manufacture customised extraction systems tailored precisely to our customers' requirements. For an optimal extraction solution, we also take care of pipe system design, installation and, optionally, maintenance and after-sales service.

Everything from a single source directly from our WERK.

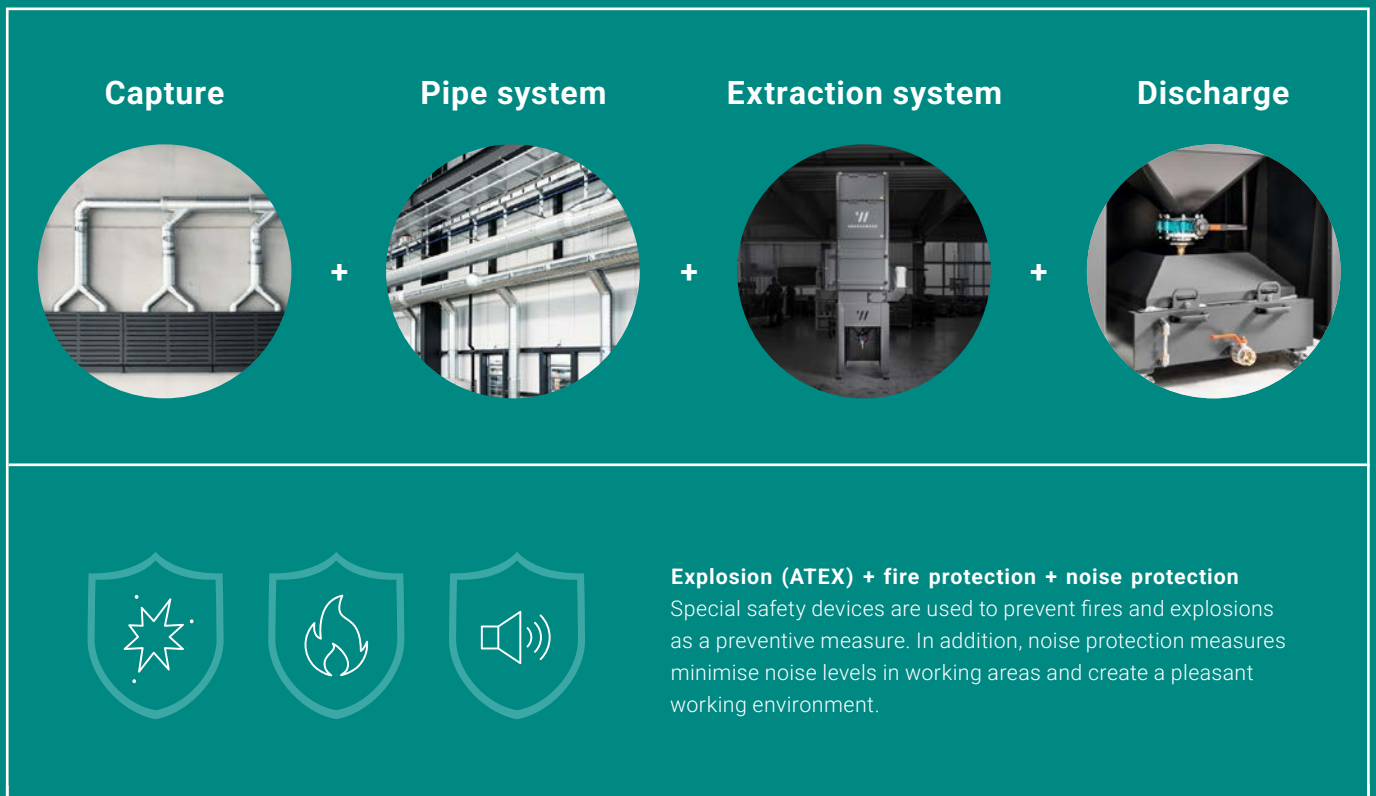

Where standard ends,  
we begin!

The result is a holistic extraction solution from start to finish. This increases performance while reducing long-term operating costs for maintenance and energy, without compromising productivity. It makes our systems a sustainable and cost-effective investment.



## Accessories & options

To configure the right extraction system for every application, we offer a wide range of options and accessories for our extraction systems. These include capture systems for precise emission extraction, various discharge solutions for safe material disposal, efficient pipe systems for optimal air guidance, as well as a filter cleaning station to extend filter service life.

This wide range of options provides maximum flexibility and adaptability to meet specific requirements such as process, material, and environment, ensuring reliable air cleaning.

Capture systems,  
discharge solutions,  
pre-separators,  
Cleanbox, pipe systems,  
etc.

Available in numerous  
sizes & variants!



### Extraction arms

Extraction arms are used for the local capture of emissions directly at the point of origin. The flow-optimised design with low resistance prevents deposits and ensures consistently high extraction performance. Particularly smooth-running joints allow easy and precise positioning. Ergonomic handles, a large working radius, as well as optional switches, LED lighting and various capture hoods provide a high level of operating comfort.



### Extraction hoods

**Overhead hoods** are used for rising media with small particle sizes. They are available in various sizes with different mounting systems and accessories such as louvers or spark arresters.

**Side hoods** are ideally suited for horizontal or lateral emission sources. The rectangular hoods are versatile in use and can be operated open or equipped with protective or deflection plates.



## Absaugtische

Extraction tables are used as workbenches for tasks such as grinding, sawing or welding. They safely and efficiently capture dust, fumes or chips directly at the source. Coarse material falls directly downwards into a discharge bin, while fine particles are captured via the rear or side panels and filtered in an extraction system. Thanks to the flexibly foldable side panels, even large workpieces can be processed without difficulty.

The WT Series extraction tables are ergonomically designed and available in various sizes. They offer numerous options such as LED lighting (also ATEX), hydraulic height adjustment, wheels for mobile use, tool holders, a roof or vice mount. Generous legroom and comfortable operation make them the ideal workbench for clean and safe processing.

---

**Height-adjustable workbench**

---

**Ergonomic with generous legroom**

---

**Ideal for small series & special parts**

---

**Flexibly foldable side panels**

---

**Easy discharge & disposal**

---

**Individually configurable & expandable**

---

**Various worktop options available**

---

**Quality »Made in Germany«**

WT Series extraction tables are available with various worktop options:



Grating



Plastic



Plasma



Wood

## Pipe system

Not only the extraction system itself determines efficiency – the pipe system also has a significant impact on air performance, operational safety, and follow-up costs. If dust or chips accumulate in the pipes, extraction performance decreases noticeably while the risk of fire and explosion increases at the same time. For this reason, we design each pipe system individually and take numerous parameters into account to provide you with the most economical solution.

Only high-quality systems are used, such as spiral pipes, beaded spiral pipes, longitudinally folded pipes, or longitudinally welded steel pipes with flanges. This ensures permanently stable, safe, and efficient systems that are optimally adapted to your processes.



## Cleanbox

The Cleanbox from ABSAUGWERK is the practical solution for cleaning stainless-steel mesh filters, as used in wet separators to reliably separate entrained water droplets and mist.

Inside the Cleanbox, the filters are securely fixed using lockable tension latches, thoroughly rinsed, and then conveniently dried on a grating. Removable rear and side panels prevent splash water and ensure that employees and the production environment remain dry and clean. Regular cleaning of the stainless-steel mesh filters with a high-pressure cleaner significantly extends their service life while reducing operating costs.



---

**Splash protection for surroundings**

---

**Safe disposal of materials**

---

**Suitable for all filter manufacturers**

---

**Lockable tension latches for grip**

---

**Removable rear and side panels**

---

**Mobile & compact**

---

**Fully disassemblable**



## Extraction cabins

Extraction cabins enable particularly efficient and energy-saving capture, as only a limited air volume needs to be circulated and filtered. Crossflows caused by doors, windows or movements within the hall are significantly reduced, resulting in much more stable capture performance. At the same time, *statutory workplace exposure limits\** statutory workplace exposure limits\* can be met more easily and cost-effectively. Noise and heat generated by many processes are also effectively contained within the cabin and continuously reduced.



## Hall extraction

For large production areas, hall extraction with a central system and pipe system provides comprehensive air cleaning. Multiple workstations can be captured simultaneously and the entire hall air is continuously filtered. This enables the efficient removal of high pollutant loads. In recirculating air operation, the system operates particularly energy-efficiently and sustainably reduces operating costs.

We aim to cover every requirement and, in addition to standard versions, also offer *cost-effective customised solutions.*



*\* Companies are responsible for ensuring that statutory workplace exposure limits in accordance with TRGS 611, TRGS 900, TRGS 910, etc. are complied with in order to minimise risks to employees.*



*Our sludge containers hold up to 220 litres of water and 55 litres of sludge. They save up to 5,200 litres of water per year and significantly reduce disposal costs.*

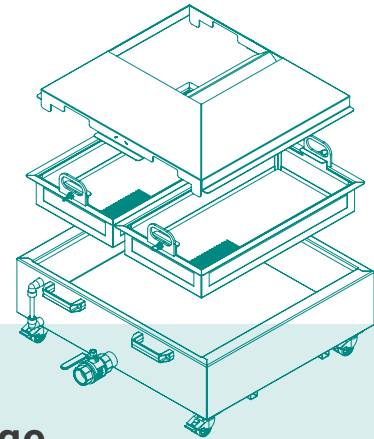

## Discharge

Depending on the production process and material, varying amounts of separated sludge are generated. The innovative design of our discharge containers efficiently separates the water from the sludge, allowing it to be returned directly to the wet separator via an optional conveying pump. This significantly reduces water and disposal costs while simultaneously protecting the environment.

Our sludge containers are available in various sizes and configurations – mobile or stationary, depending on requirements.



# real. sustainable.

## SUSTAINABLE EXTRACTION SOLUTIONS

Thanks to their high separation efficiency, our wet separators are ideally suited for *air recirculation mode\**, even in processes involving carcinogenic substances. A frequency inverter adjusts the extraction performance according to demand and saves energy. From the very beginning of the development process, we focus on minimal flow resistance and efficient air guidance. The result: powerful systems with very low energy consumption and a particularly durable, sustainable design. In this way, our wet separators make an important contribution to resource-efficient and energy-efficient production.

## RESPONSIBILITY WITHIN THE COMPANY

All of our entrepreneurial activities are based on ecological, social and economic responsibility. Clean air in production halls protects the health of employees, helps prevent illness and makes workplaces safer. At the same time, machinery, tools and workpieces are protected, significantly extending their service life and increasing the economic efficiency of the entire operation.



*\* The cleaned air is so clean that it can be returned directly to the working environment. Our circulation system also enables efficient recirculation of the water separated from the sludge back into the wet separator.*

## Ihre Vorteile

---

**High-quality & durable**

---

**Low energy & operating costs**

---

**Low maintenance & personnel-friendly**

---

**Cleanable permanent filters**

---

**Flexible system components**

---

**Winter/summer mode (opt.)**

---

**Frequency inverter (opt.)**

---

**Cross-flow heat exchanger (opt.)**

---

**Primary explosion protection**

# Ex-Protection

In many industrial processes, flammable or explosive substances such as gases, vapours, mists or dusts are generated. When they come into contact with oxygen and an ignition source, an explosive atmosphere can form very quickly, with devastating consequences for people, machinery and operations.

The extraction systems from ABSAUGWERK are designed to prevent the formation of such atmospheres as a preventive measure. Thanks to their high separation efficiency, constant extraction performance, optimised air guidance and ATEX-compliant construction, they meet the requirements of **primary explosion protection**.

The water wall of the wet separator reliably extinguishes or neutralises potential ignition sources. This prevents ignition and eliminates the need for additional explosion protection measures. As a result, ATEX systems from ABSAUGWERK can be manufactured up to 50 % more economically, while operating and maintenance costs are permanently reduced.



## Legal requirements

Within the European Union, the ATEX Directives govern all requirements and specific aspects of explosion protection. They distinguish between manufacturers and operators, and compliance by both parties is essential to ensure long-term safety and occupational health protection. When designing our extraction systems, we take all relevant parameters into account, assess them in accordance with legal requirements and manufacture ATEX-compliant systems precisely tailored to the respective application.

EC DIRECTIVE	RESPONSIBILITY
2014/34/EU (ATEX 114)	Manufacturer
1999/92/EG (ATEX 137)	Operator

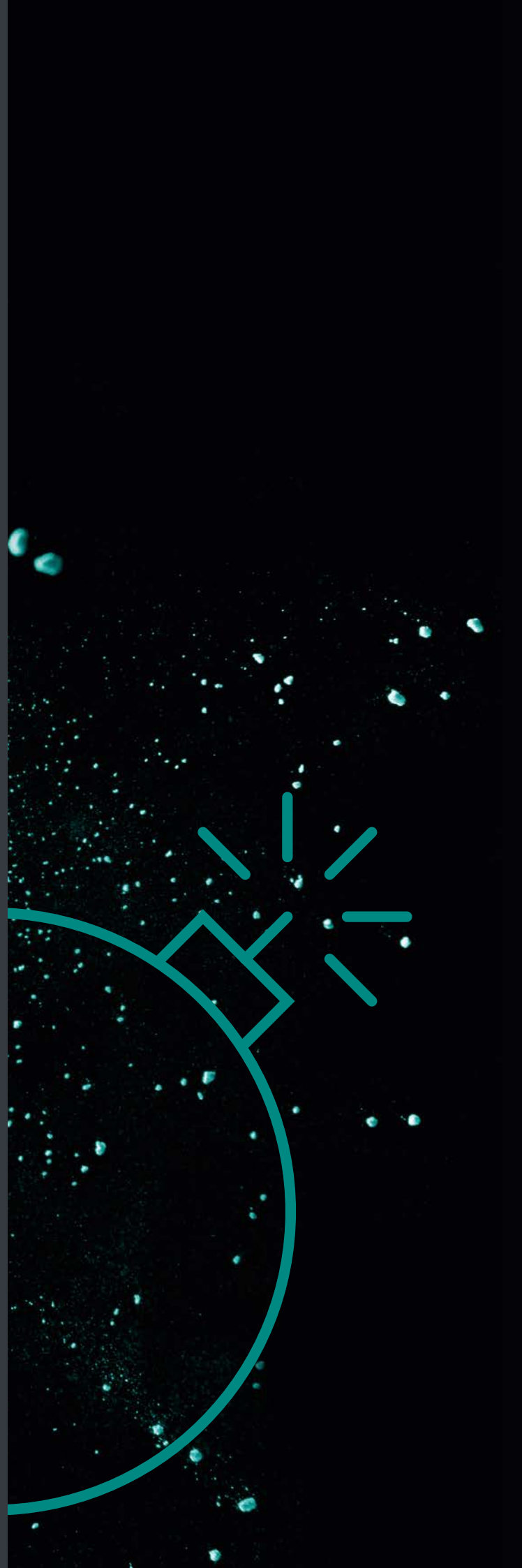



Our ATEX systems proactively prevent the formation of explosive atmospheres!

Through various **ATEX measures** and an innovative design, we ensure the safe operation of our systems:

- Air velocity in pipe system  $\geq 20$  m/s
- Secured airflow monitoring
- ATEX Zone 2 motor
- Ignition-source-free and conductive design
- No hazardous zones during operation
- Electrical components installed in accordance with ATEX
- Control cabinet located outside the system
- Automatic extinguishing systems in accordance
- Coated impellers



## Your benefits

---

**Savings of up to 50%**

---

**Low operating & follow-up costs**

---

**Maximum extraction performance**

---

**Maximum separation efficiency**

---

**Safe operation**

---

**Highest quality standards**

---

**Suitable for indoor installation**

# Fire protection

In processes with a high level of flying sparks or when processing flammable materials such as aluminium, titanium or magnesium, there is an increased risk of fire. Even the smallest sparks or glowing particles can settle unnoticed in deposits within the pipe system or inside the system and form smouldering nests there, which are one of the most common causes of subsequent fires.

Wet separators offer a decisive safety advantage in this context: they immediately extinguish sparks and hot particles in water before they can reach an ignition source. The water-based separation process also eliminates the use of flammable filter media, significantly reducing the risk of fire. In combination with modern monitoring systems, this ensures maximum operational safety and preventive fire protection in demanding manufacturing environments.



## Legal requirements

### RESPONSIBILITIES OF OPERATORS & MANUFACTURERS

As part of a risk assessment (*suitability of the machines for the intended process*) and the preparation of an explosion protection document, the operator is required to assess whether there is a potential risk of fires or explosions.

**The operator** is required, as part of a risk assessment (assessment of the suitability of the machines for the intended process) and the preparation of an explosion protection document, to evaluate whether there is a potential risk of fires or explosions.

**The manufacturer** takes this information into account when defining an appropriate protection concept for the machine tool and aligns the operating and maintenance instructions accordingly.

Even though wet separators are based on a water-based separation principle, hazardous situations can arise if they are operated improperly, insufficiently maintained or used under unfavourable process conditions. Particle deposits, contaminated process water or system components that are not cleaned regularly can impair the protective effect and, in the worst case, lead to a risk of fire or explosion.

An effective fire protection concept for wet separators therefore does not begin with additional safety devices alone, but primarily with consistent maintenance and cleaning. Regular inspection, cleaning and the proper replacement of water, separation elements and safety-relevant components are among the most important measures for safe operation. This prevents the accumulation of flammable substances, ensures a permanently stable separation performance and guarantees the protective function of the wet separator at all times.



## CHECKLIST

- Hazard assessment conducted by an accredited fire protection and explosion protection officer
- Availability of fire protection regulations
- Operation of the system only by trained personnel
- Regular fire protection drills
- Availability of a fire extinguisher
- Annual maintenance and cleaning of the system
- Regular emptying of the discharge



### Knowledge

#### PREREQUISITES FOR A FIRE

For a fire to occur, three conditions must be met simultaneously: oxygen, fuel and an ignition source. In metalworking processes, these factors are often present: flammable dusts or deposits act as fuel, the surrounding air supplies oxygen, and sparks, hot surfaces or friction serve as ignition sources. When these elements come together, even the smallest smouldering nests can develop into an open fire. Regular inspection and cleaning are therefore crucial in order to permanently prevent this dangerous combination.

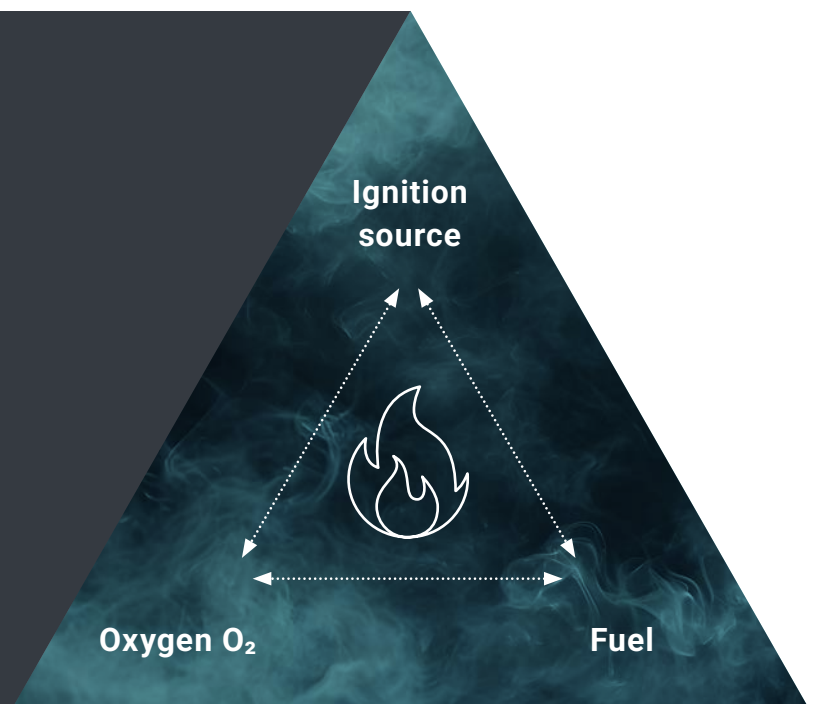

# Noise protection

Noise is one of the most common health risks in the workplace. Continuous exposure can lead to hearing damage, stress and impaired concentration. That is why our extraction systems are designed to operate particularly quietly and can be equipped with additional noise protection components – ensuring that noise exposure remains reliably below statutory limit values.

## LIMIT VALUES & MEASURES

A daily noise exposure level LEX,8h **of 80 dB(A)** or a peak sound pressure level LpCpeak **of 135 dB(C)** requires:

- Information for employees  
*(when the action value is reached)*
- Provision of hearing protection  
*(when the action value is exceeded)*
- Offer of occupational medical health surveillance  
*(when the action value is exceeded)*

A daily noise exposure level LEX,8h **of 85 dB(A)** or a peak sound pressure level LpCpeak **of 137 dB(C)** requires:

- Mandatory use of hearing protection  
*(when the action value is reached)*
- Initiation of occupational medical health surveillance  
*(mandatory surveillance when the action value is reached)*
- Identification and marking of noise areas  
*(when the action value is exceeded)*
- Implementation of a noise reduction programme  
*(when the action value is exceeded)*



## Legal requirements

Workplace Ordinance  
*ArbStättV*

Noise and Vibration Occupational Safety Ordinance  
*LärmVibrationsArbSchV*

Technical Rules for the Noise and  
Vibration Occupational Safety Ordinance  
*TRLV Noise*

## Your benefits

---

**Optimised flow geometry**

---

**Smooth-running compressors**

---

**Maximum extraction performance**

---

**Low energy consumption**

---

**Noise exposure below 80 dB(A)**



We offer a range of specialised **noise protection components** that can be precisely adapted to the process, room size and system performance, including:

- Baffle silencers
- Duct silencers
- Machine enclosures
- Noise protection cabins

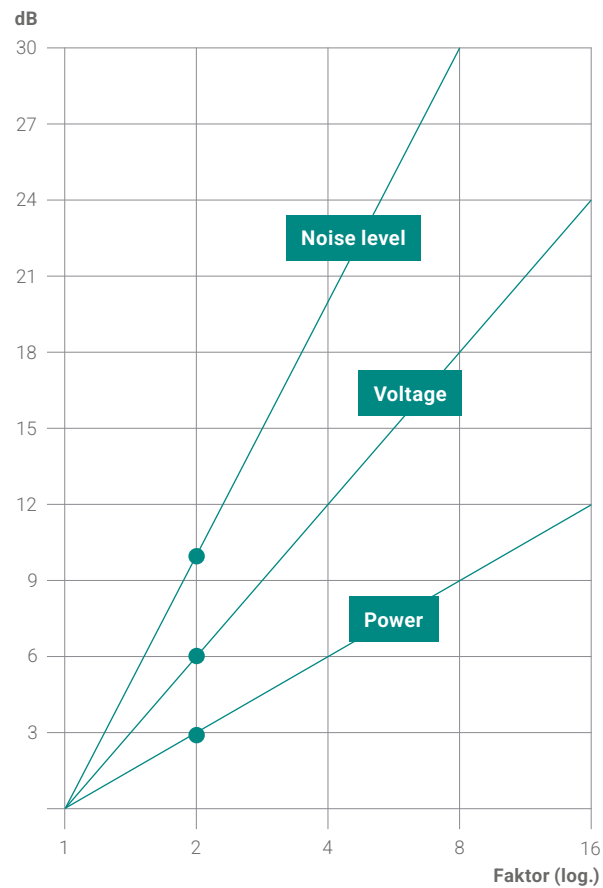

*An increase in the noise level of just 3 dB already means a doubling of the sound power and is perceived as significantly louder.*

**+3 dB** = double sound power

**+6 dB** = double sound pressure

**+10 dB** = double perceived loudness

# Technical Data

7 different size variants  
15 power levels

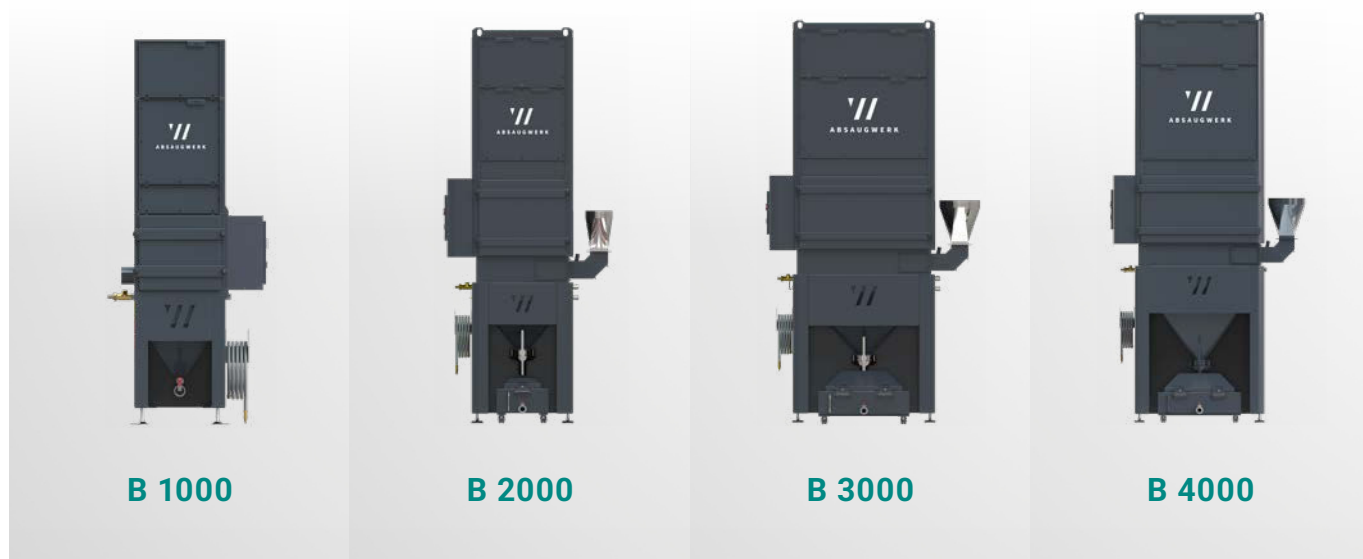

## B Series 1000–3000

NASSABSCHIEDER SERIE		B 1000	B 2000	B 2000	B 2000	B 3000	B 3000	B 3000
Motor power	kW	1.1	2.2	3	4	4	5.5	7.5
Max. fan power	m³/h	2,350	3,400	4,200	6,200	6,200	6,900	11,000
Width (b)	mm	550	850	850	850	1,250	1,250	1,250
Depth (t)	mm	650	850	850	850	850	850	850
Height A (cone)	mm	900	2,700	2,800	2,800	2,920	3,020	3,120
Height B (cone + H14)	mm	2,025	2,215	2,275	2,770	2,890	2,890	3,030
Height A (cone with elevation)	mm	2,390	2,915	3,015	3,015	3,135	3,235	3,235
Height B (cone with elevation + H14)	mm	–	3,000	3,100	3,100	3,220	3,320	3,420
Height C (slotted silencer)	mm	(+800)	(+1,000)	(+1,000)	(+1,000)	(+1,000)	(+1,000)	(+1,000)

Status January 2026 | Subject to change

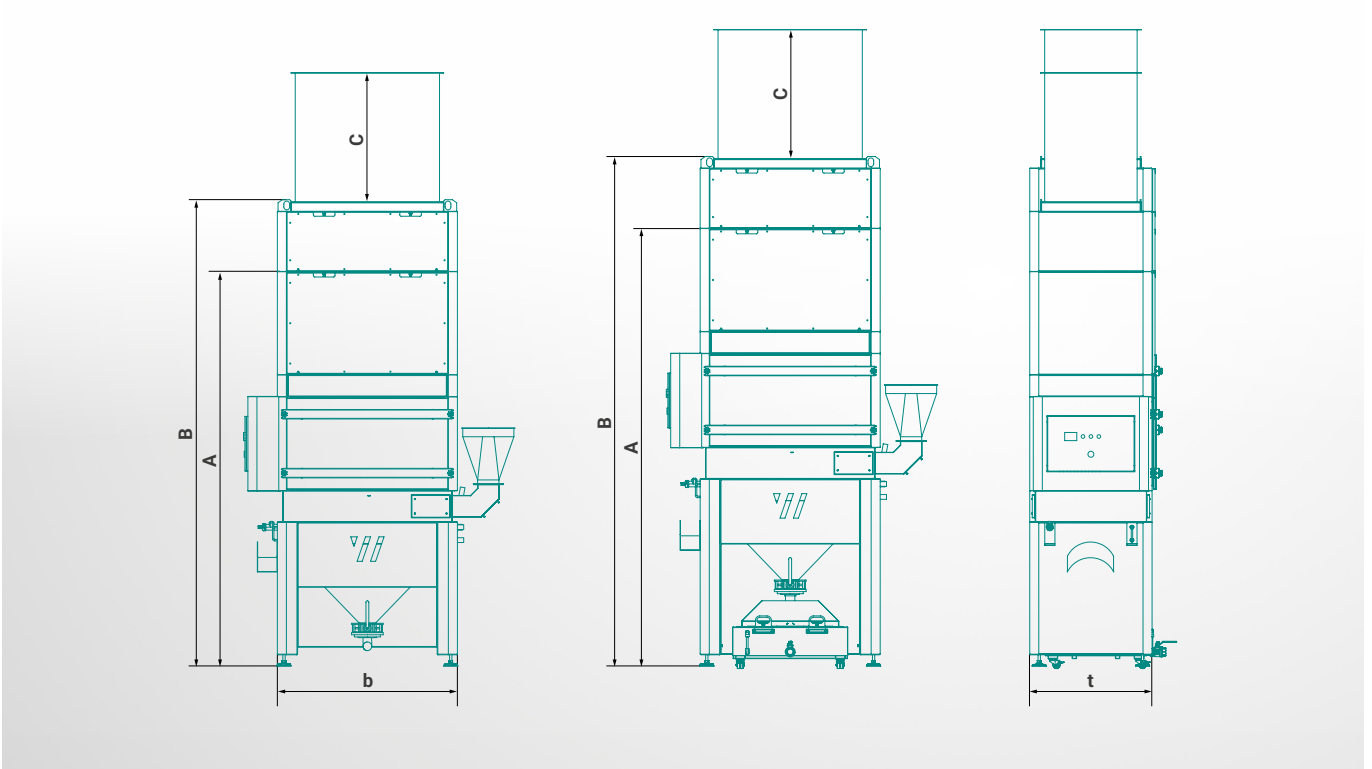

## B Series 4000–5000

NASSABSCHIEDER SERIE		B 4000	B 4000	B 5000	B 5000
Motor power	kW	11	15	18.5	22
Max. fan power	m³/h	14,800	18,000	21,000	22,000
Width (b)	mm	1,250	1,250	1,800	1,800
Depth (t)	mm	1,500	1,500	1,500	1,500
Height A (cone)	mm	3,520	3,520	3,880	3,880
Height B (cone + H14)	mm	3,635	3,635	3,995	3,995
Height A (cone with elevation)	mm	450	550	550	550
Height B (cone with elevation + H14)	mm	3,820	4,160	4,160	(+550)
Height C (slotted silencer)	mm	(+1,000)	(+1,000)	(+1,000)	(+1,000)

Status January 2026 | Subject to change



# Reference

Wet separators in a double configuration for QUADRUS Metalltechnik

Quadrus Metalltechnik GmbH is a family-owned company based in Schmidgaden, specialising in laser technology, forming technology, welding technology and assembly. Up to 1,100 tonnes of steel, stainless steel and aluminium are processed every month. Processes such as welding, laser cutting, forming and deburring generate hazardous and explosive dusts that must be reliably extracted. For the extraction of two Timesavers deburring machines as well as for production at an extraction table, Quadrus relies on our specialised ATEX wet separators.

»ABSAUGWERK stands out due to very high extraction performance and excellent service.«

*Hans Maier,  
Operations Manager Quadrus Metalltechnik GmbH*

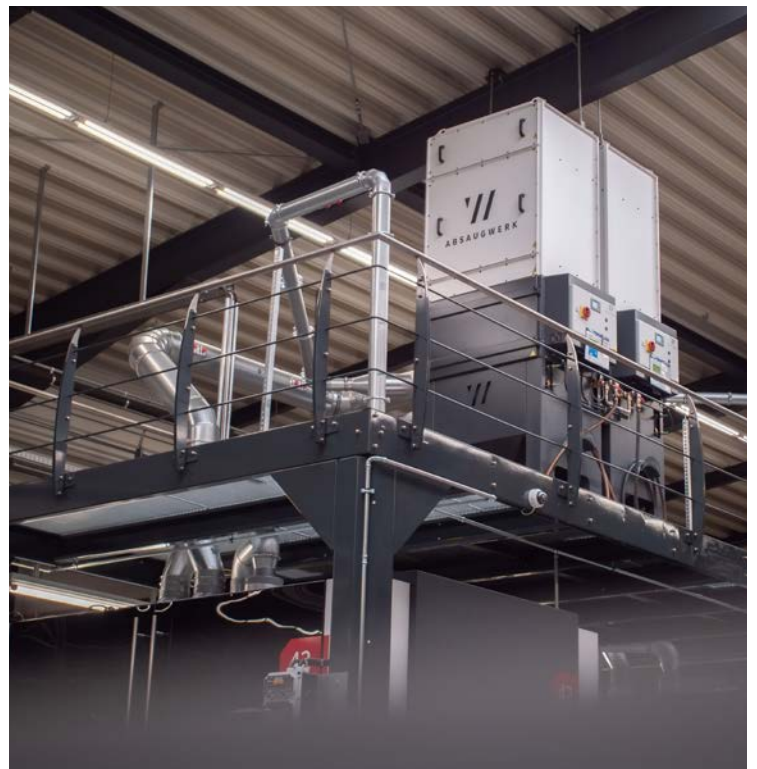

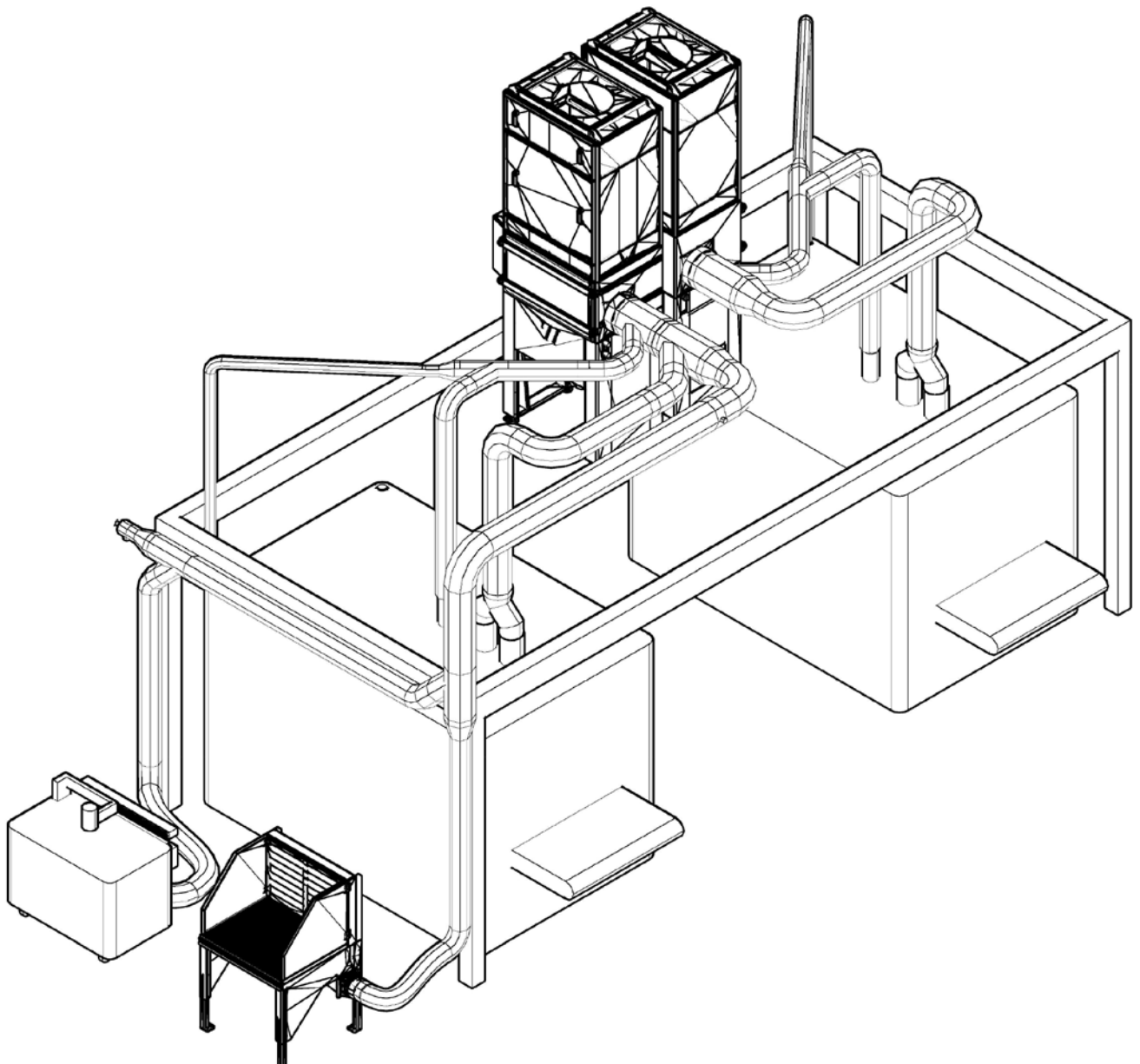

### CHALLENGE

At Quadrus, two deburring machines and two manual workstations needed to be extracted efficiently and safely while processing a material mix of stainless steel, steel and aluminium. The requirement was a space-saving, low-maintenance solution with simple emptying and low operating costs.

### SOLUTION

To ensure safety and efficiency, ABSAUGWERK installed two ATEX wet separators that extract both the deburring machines and two manual workstations. Flammable aluminium dusts are bound in water, while carcinogenic stainless-steel dusts are retained by HEPA H14 filters. The cleaned air is returned to the hall in air recirculation mode, while the separated sludge can be disposed of easily.

An extraction table of the WT series enables flexible processing of small batch sizes. A solution that perfectly combines safety, efficiency and cost-effectiveness.



The QUADRUS reference video at  
[absaugwerk.de/en/quadrus-metalltechnik](https://absaugwerk.de/en/quadrus-metalltechnik)

#### MEDIA

- Stainless-steel dusts (*carcinogenic*),
- Aluminium dusts (*explosive*)

#### PROCESSES

- Deburring, grinding, edge rounding

#### PERFORMANCE

- Motor power: 2 × 11 kW
- Max. air volume: 2 × 10.000 m<sup>3</sup>/h

#### SERVICE

Personal consultation, technical design, pipe system planning, production, installation, pipe system, commissioning, maintenance and after-sales support



**»It was important to us to create clean, dust-free ambient air with optimal employee protection and manageable operating costs.«**

*Hans Maier,  
Operations Manager QUADRUS Metalltechnik GmbH*



**Fig. 1**  
W series 3000, 5,5 kW

**Process:** Deburring  
**Material:** Aluminium, stainless steel  
**Medium:** Dry dust  
**Capture:** Direct connection  
**Discharge:** Sludge container

**Fig. 2**  
W series filter unit 3000, 11 kW

**Process:** Deburring  
**Material:** Aluminium, stainless steel, carbon steel  
**Medium:** Dry dust  
**Capture:** Direct connection  
**Discharge:** Sludge container

**Fig. 3**  
B series 2000, 5,5 kW

**Process:** Grinding  
**Material:** Aluminium  
**Medium:** Dry dust  
**Capture:** Direct connection  
**Discharge:** Sludge container

**Fig. 4**  
B series 3000, 7,5 kW

**Process:** Deburring  
**Material:** Aluminium, stainless steel, carbon steel (alternating operation)  
**Medium:** Dry dust  
**Capture:** Direct connection  
**Discharge:** Sludge container

# 360° all-round service

## Consulting

Free needs analysis and individual quotation by our sales team.

## Marketing

Support in marketing through videos as well as customised design and branding.

## Project planning

Personal support including an on-site inspection and the specification of technical parameters.

## Training

Introduction to system components and performance of minor service and maintenance tasks.

## Installation

Delivery and installation of the extraction system, including installation of the pipe system.

## After-Sales

The full range: Spare and wear parts, cleaning, training, repairs and retrofitting.

## Commissioning

Mechanical and electrical system briefing covering functionality, safety and control.

## Maintenance

Comprehensive service for third-party and in-house systems to ensure smooth operation.

**We keep  
your WERK  
running!**

## Your benefits

Everything from a single source

In-house & third-party maintenance

Free process analysis

Personal on-site appointment

Smooth & safe operation

Avoidance of downtime & follow-up costs

Worldwide support

Remote diagnostics & maintenance

# Maintenance

Unplanned system downtime can not only cause high costs, but also put employee safety at risk. To ensure that your extraction systems operate efficiently and reliably over the long term, ABSAUGWERK offers a comprehensive maintenance service. Regular inspections allow technical deviations to be identified at an early stage, before they develop into costly or safety-critical issues. Our many years of expertise and a well-structured service organisation ensure short response times and rapid fault resolution.

## REMOTE MAINTENANCE – WORLD WIDE WERK

In automated production environments, reliability is essential. Our remote maintenance systems monitor system parameters in real time and automatically notify us of critical deviations. This enables our service technicians to respond immediately, regardless of location. Intelligent monitoring, modern alarm functions and secure VPN encryption provide fast support, protect your data and offer maximum flexibility at the same time.

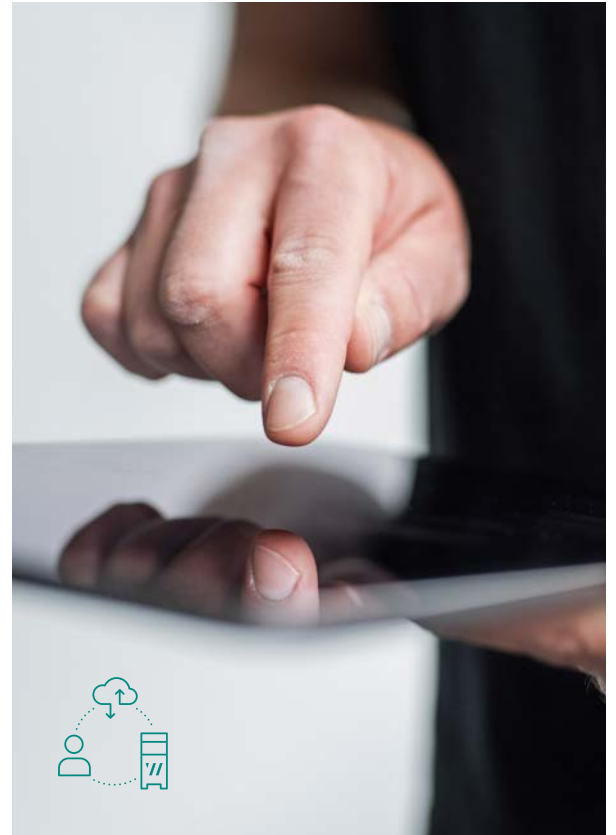

We service both in-house and third-party systems.  
You only need one appointment and one site visit!

Request your non-binding maintenance offer:  
[sales@absaugwerk.de](mailto:sales@absaugwerk.de)





# Quality from Neu-Ulm!

Our WERKER are professionals in their field and see themselves as part of the overall WERK. With more than 200 years of combined experience in extraction technology, we create durable and robust extraction systems handcrafted and »MADE IN NEU-ULM«! Every system undergoes strict quality and safety testing before it leaves our WERK.

We continuously invest in training and technology to keep moving the market forward. Our innovative strength has been recognised with the BSFZ seal – a mark of research-based development and publicly funded innovation. Our goal: better working conditions, sustainable environmental protection and your success with perfect workpieces.

We configure extraction systems individually and provide premium service directly from our WERK. That's what makes our solutions **real. better.**



Every WERKER considers themselves part of a responsible society and a healthy environment.



## Learn what matters in extraction technology!

Effective extraction is essential for safe and healthy working environments. We inform you about relevant workplace exposure limits and legal requirements, and show you which solutions best suit your processes.

You will also get to know the various components of our systems: we explain what matters in system design, planning and maintenance, and provide practical tips for minor service tasks.

For our OEM and distribution partners, we offer customised training programmes, either directly at your site or at our WERK in Neu-Ulm.

**Feel free to contact us:**

**[info@absaugwerk.de](mailto:info@absaugwerk.de) | +49 731 141 108-0**

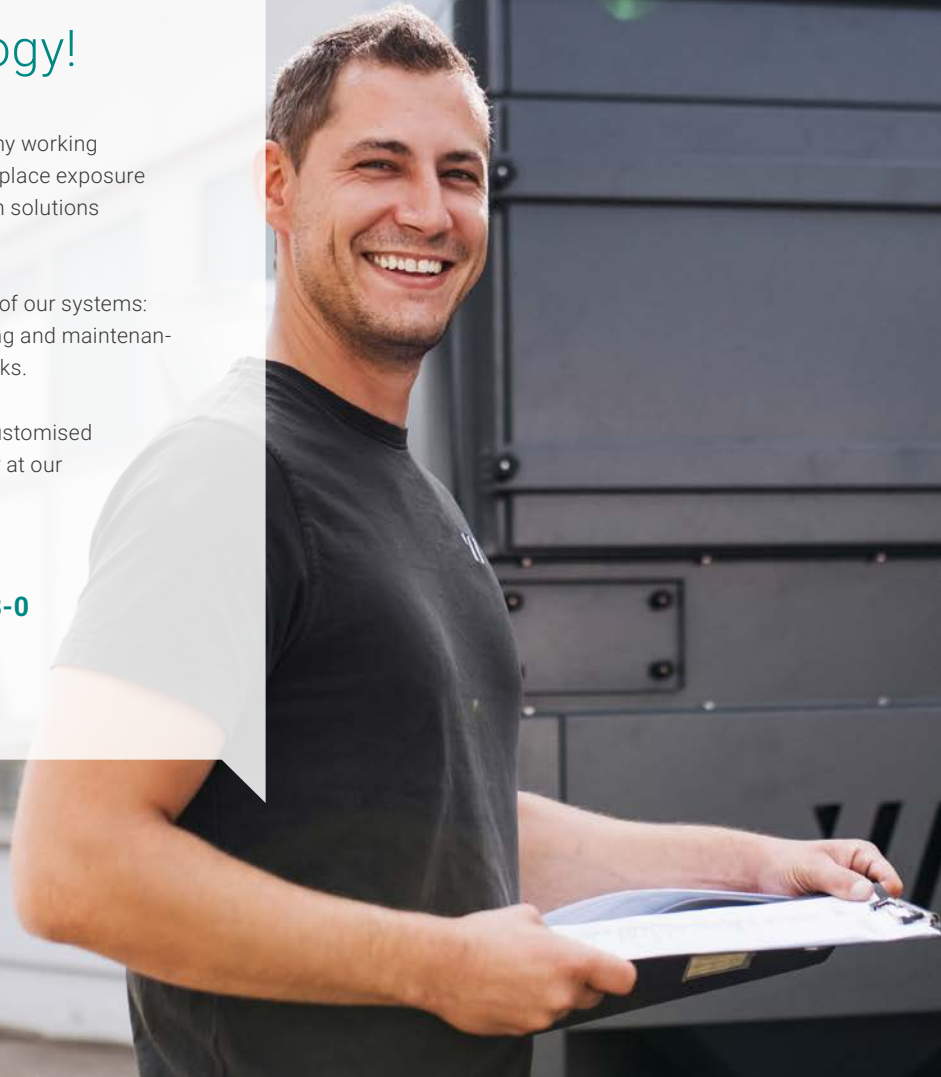

# real. personal.

ABSAUGWERK stands for lived values that go far beyond technology. Our employees share not only expertise, but also common values of teamwork, responsibility and trust. This culture forms the foundation of our success and our »feel-good philosophy«.

Within our network, we also focus on genuine partnerships: open, respectful and on equal footing. We believe in long-term relationships built on reliability and mutual appreciation, because only together can something be created that truly lasts.

ABSAUGWERK GmbH  
Messerschmittstr. 22  
DE-89231 Neu-Ulm

+49 731 141 108-0  
[info@absaugwerk.de](mailto:info@absaugwerk.de)  
[www.absaugwerk.de](http://www.absaugwerk.de)

**Follow us on social media:**



[@ABSAUGWERK GmbH](https://www.instagram.com/absaugwerk)



# Project process

## 5 steps to your perfect extraction solution!

- 01** **Process analysis**

In the first step, your work processes are analysed, pollutant sources are identified and existing extraction systems are reviewed in order to determine the exact extraction requirements.
- 02** **Personal on-site visit**

Our experts assess the local conditions directly at your site and take precise measurements to plan the ideal solution for your operation.
- 03** **Individual quotation**

Based on the analysis and technical drawings, you will receive a customised quotation within a short time, offering the most economical solution for your needs.
- 04** **Production**

Once the technical drawings have been approved and the order placed, we immediately begin procurement, manufacturing and scheduling for installation.
- 05** **Installation**

Our installers set up the complete extraction system, including pipe system, and support you during commissioning. Performance and functionality are carefully tested and documented – ensuring a smooth start-up.



[absaugwerk.de](https://absaugwerk.de)

real. better.