



A B S A U G W E R K

FUME FILTER
R SERIES



The WERK

As a manufacturer of industrial extraction technology, we strive for a clean and healthy working environment. Our strength lies in the in-house development and production of customised extraction systems designed to protect employees, machines and workpieces.

From industrial dedusters and oil mist separators to complete hall extraction systems, we offer a comprehensive portfolio of solutions. We combine capture elements, extraction units and pipe systems into an integrated overall system that sets new standards in terms of energy efficiency and performance. In the field of explosion and fire protection, we are one of the few providers that fully meet all legal requirements and are able to ensure safe operation. With our many years of expertise, we develop special solutions for companies of all sizes and across all industries.

The production of our high-end systems takes place at our own WERK. Here, quality and precision are our top priorities. We support our customers throughout the entire service chain – from initial consultation through to installation and beyond. This ensures that their systems always operate at optimum performance.

We place particular emphasis on maintaining our NetzWERK. Honesty, trust and personal contact form the foundation for long-term and successful partnerships.

»People, as customers, partners or employees, are always at the heart of our company.«

Michael Werz, Managing Director

Introduction	1
<hr style="border: 1px solid #008080;"/>	
Fume filter	3
Applications & components	5
Functionality	7
The ABSAUGWERK Principle	8
Accessories & options	9
Product variant SmartX	15
Sustainability	16
Explosion protection	17
Fire protection	19
Noise protection	21
Technical data	23
Reference	25
<hr style="border: 1px solid #008080;"/>	
All-round service	29
Quality	32
Training & partnership	33
Project process	34

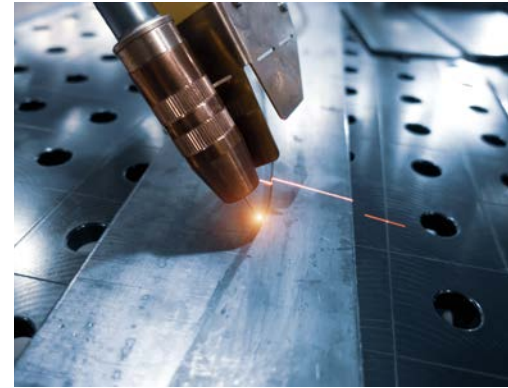



Welding fumes are harmful!

PROBLEM

In metalworking processes such as welding, laser processing, cutting or soldering, fumes, smoke and extremely fine metal particles are generated and released into the breathing air.

Stainless-steel alloys are particularly critical, as their chromium and nickel content can release hazardous substances, some of which are carcinogenic. Emissions from welding processes are classified worldwide as carcinogenic (*IARC, Group 1*), meaning substances for which there is clear scientific evidence that they can cause cancer.

Studies show that even low concentrations of chromium (VI) and nickel can significantly increase the risk of lung cancer. According to a recent study, the mortality risk from lung, bronchial and tracheal cancer among welders is around **25 % higher*** than in the general population.

Without effective filtration, these pollutants enter the breathing air and pose a long-term risk to employee health. With high-quality capture systems, these hazards can be reliably reduced and the air quality in production can be demonstrably improved.

** Source: Environmental Research, Vol. 245, 2024, ScienceDirect – DOI: 10.1016/j.envres.2024.118021*

FUME FILTER

R Series

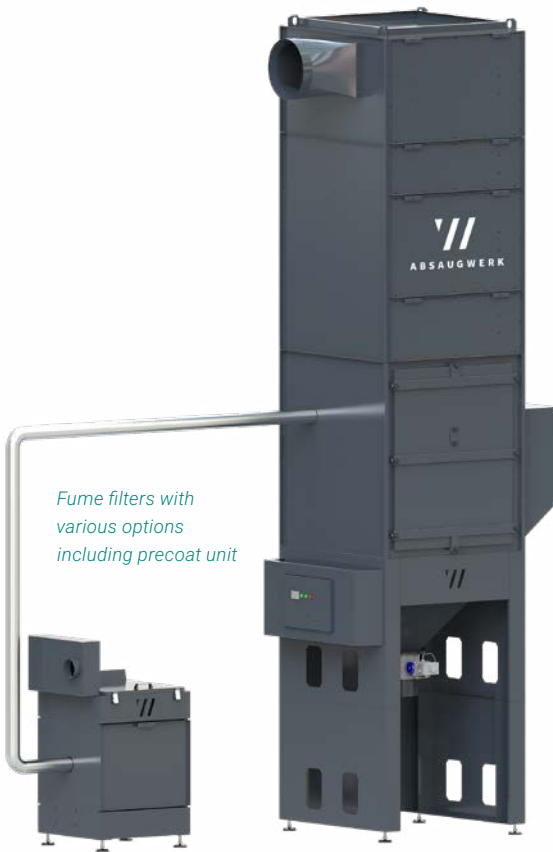

SOLUTION

Fume filters from ABSAUGWERK capture welding fumes, smoke and fine metallic dusts directly at the source before they enter the breathing air. Multi-stage filter systems reliably separate even the finest particles and hazardous emissions. For processes involving stainless steel, versions with W3 certification for mobile extraction systems or HEPA H14 filters are used, which safely retain carcinogenic substances such as chromium (VI) or nickel.

The cleaned air can either be returned to the production hall in air recirculation mode or discharged outside in exhaust air mode. Thanks to energy-efficient control, optional performance regulation via a frequency inverter, and a low-maintenance design, our fume filters operate particularly economically. They ensure clean air, healthy employees and a safe production environment.



Performance:

2,400–40,000 m³/h*

1.1–45 kW

** Systems connected in series have the potential to deliver virtually unlimited performance.*

Your benefits

High extraction power

Low energy consumption

Cleanable permanent filters

Durable filter components

Easy cleaning & maintenance

Individual configuration & special solutions

Recirculating air & exhaust air operation

Versatile control functions

Remote maintenance & remote access

Exclusive design

Application

During tack welding, laser processing, cutting or robotic welding, sparks, hot particles and fine dusts are generated. Especially when welding aluminium or stainless steel, toxic fumes containing chromium and nickel compounds are produced, which are highly hazardous to health. Our fume filters are used wherever clean air and safe processes are indispensable – for example in metalworking, the automotive industry, mechanical and plant engineering, or the aerospace industry.

INDUSTRIES

Automotive, chemical industry, food industry, metal processing, pharmaceutical industry, etc.

PROCESSES

- Tack welding
- Soldering
- Laser processing
- Marking
- Cutting
- Robotic welding
- Welding, etc.

MEDIA

- Fumes
- Smoke

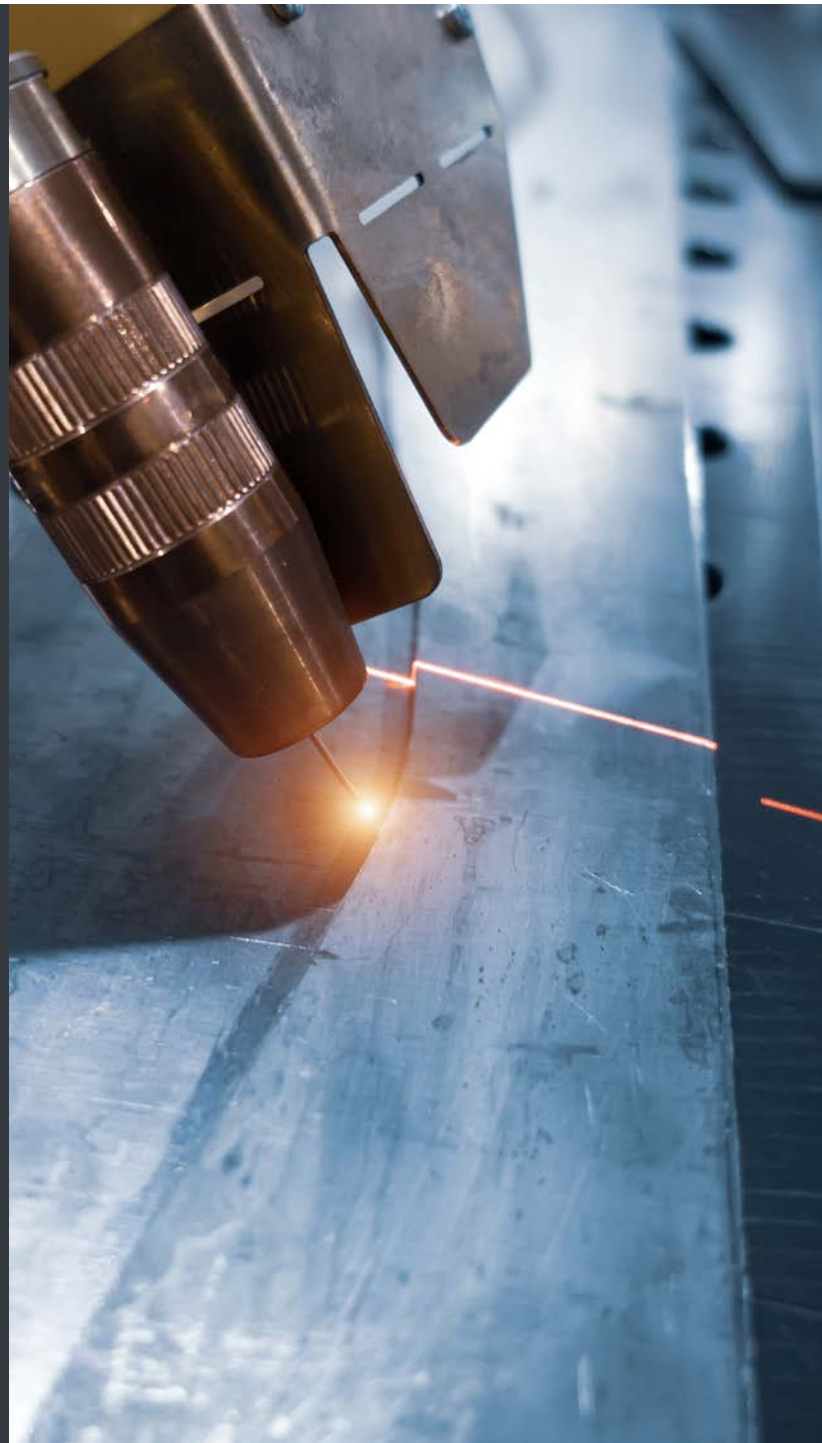

Filter:

- Cartridge filters

Discharge:

- Drawer
- Bin
- Bucket
- Container
- Automatic discharge (*rotary valve*)
- Individual discharge

Capture:

- Extraction arm
- Extraction table
- Extraction hood
- Pipe system
- Machine connection
- Room capture
- Individual capture

Equipment:

- 11 power levels
- 2 filter stages
- Jet pulse filter cleaning
- IE3 to IE5 motors

Components

The fume filters are individually designed for the respective process. Multi-stage filter systems with pre-separators, cartridge filters and optional HEPA H14 filters reliably remove pollutants from the air. Activated carbon filters additionally neutralize gases and odors. Efficient fans and precisely coordinated components ensure maximum performance with minimal energy consumption. Optionally, the system can be equipped with a high-performance high-vacuum fan.

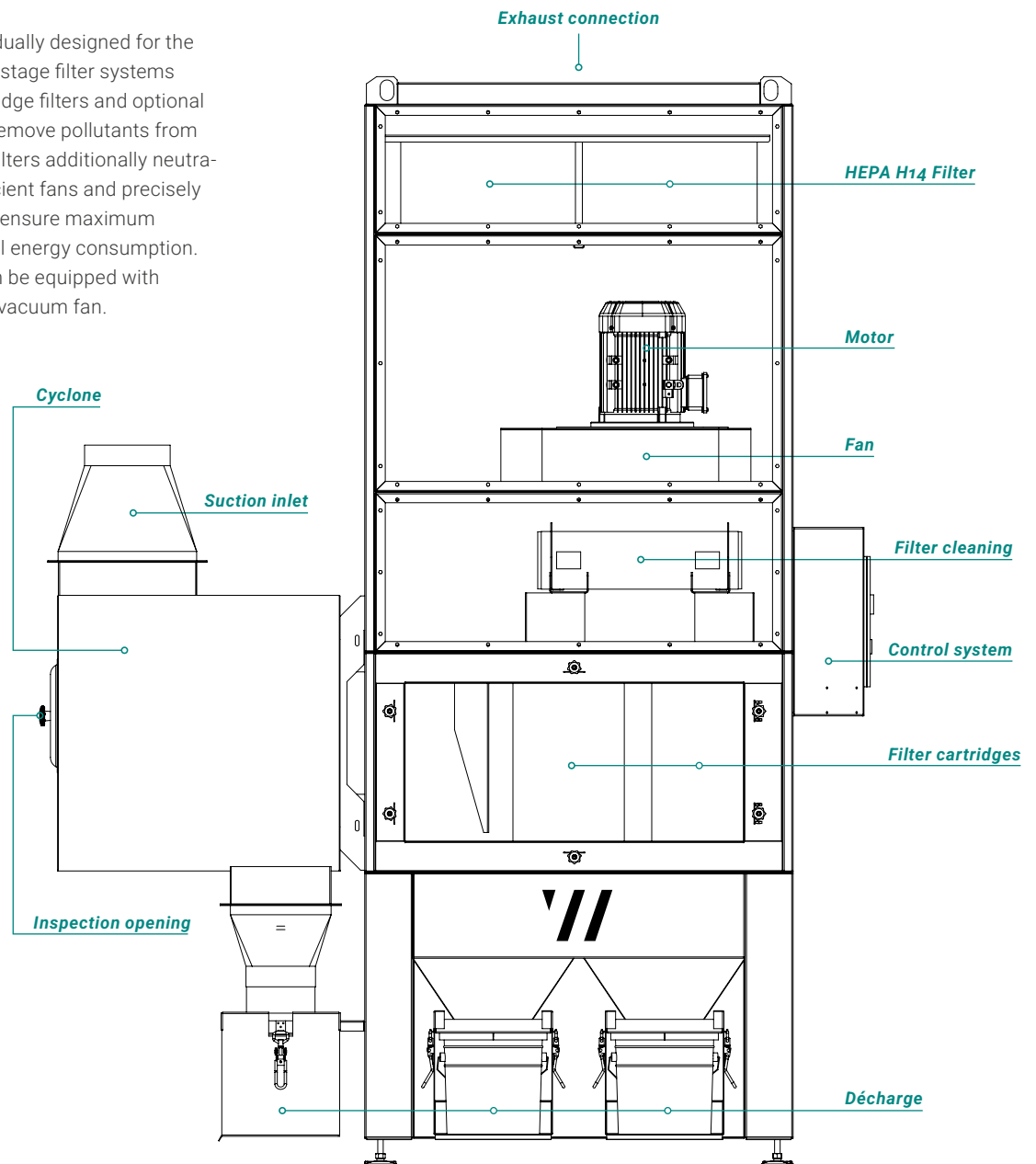

Options:

- HEPA H14 filter for carcinogenic substances in recirculating air operation
- Activated carbon filter for gases and odours
- ATEX / fire protection version
- W3 version for mobile systems
- Pre-separator
- Effective noise protection
- Cross-flow heat exchanger
- Precoat unit
- Various fans (*medium pressure, high pressure, high vacuum*)
- Versatile intelligent controls
- Individual system colour & branding



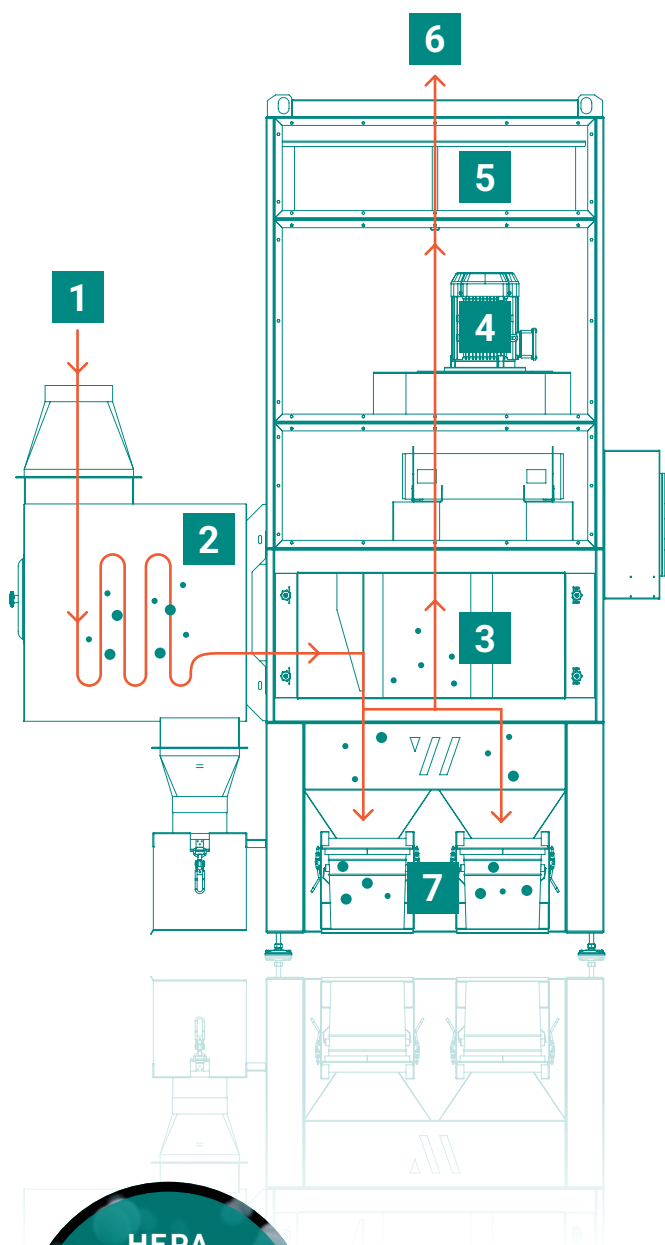

Functionality

The air is captured directly at the source, filtered in several stages and cleared of smoke and particles. It can then be safely returned in recirculating air or exhaust air operation.

1. SUCTION

Contaminated air is extracted via a direct machine connection or another capture system.

2. PRE-SEPARATOR

A pre-separator removes a large proportion of medium-sized and coarse particles, smoke and sparks. This protects the main filters and significantly extends their service life.

3. FILTER STAGE 1

Fine dust is reliably separated using cartridge or hose filters. Filter cleaning is carried out automatically via jet pulse cleaning.

4. FAN

The fan with IE3 technology, optionally available with IE4 or IE5, operates extremely quietly, efficiently and with high performance.

5. FILTER STAGE 2

For particularly fine or carcinogenic substances such as stainless steel, an additional HEPA H14 filter is used to reliably capture even microscopic particles.

6. EXHAUST

The cleaned air is either discharged outside or returned to the room in recirculating air operation, reducing heating and energy costs.

7. DISCHARGE

The separated dust is disposed of individually via drawers, bins, buckets or containers. Alternatively, automatic discharge is carried out via a rotary valve.

HEPA H14 FILTER

Filters 99,995% of all fine particles and viruses

With a separation efficiency of 99.995%, HEPA H14 filters remove even ultrafine and carcinogenic particles from the air. They ensure maximum safety in processes involving stainless steel or other hazardous substances.

The ABSAUGWERK Principle

A high-performance and energy-efficient extraction system consists of several components that must work in perfect harmony. If elements such as capture systems or the pipe system reduce performance, this can not only impair functionality but also lead to deposits and dangerous fires. As every application is unique, we develop and manufacture customised extraction systems tailored precisely to our customers' requirements. For an optimal extraction solution, we also take care of pipe system design, installation and, optionally, maintenance and after-sales service.

Everything from a single source directly from our WERK.

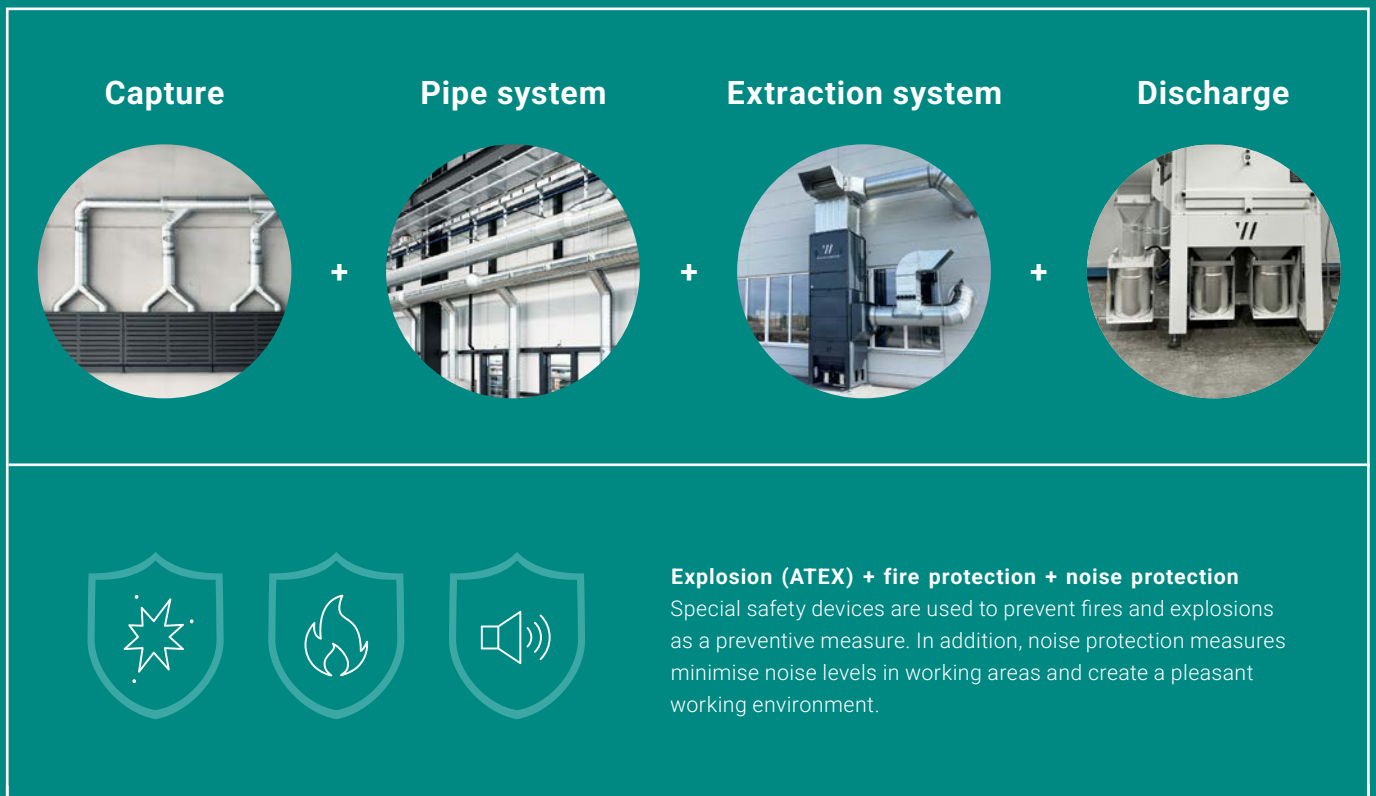

Where standard ends,
we begin!

The result is a holistic extraction solution from start to finish. This increases performance while reducing long-term operating costs for maintenance and energy, without compromising productivity. It makes our systems a sustainable and cost-effective investment.



Accessories & options

To configure the right extraction system for every application, we offer a wide range of accessories and options for our extraction systems. These include capture elements for precise emission extraction, various discharge options for safe material disposal, efficient pipe systems for optimal airflow, precoat units for filter protection as well as pre-separators to extend filter service life.

This wide range of options provides maximum flexibility and adaptability to meet specific requirements such as process, material and environment, ensuring reliable air cleaning.

Capture systems,
discharge solutions,
pre-separators,
precoat units, pipe
systems, etc.

Available in numerous
sizes & variants!



Extraction arms

Extraction arms are used for the local capture of emissions directly at the point of origin. The flow-optimised design with low resistance prevents deposits and ensures consistently high extraction performance. Particularly smooth-running joints allow easy and precise positioning. Ergonomic handles, a large working radius, as well as optional switches, LED lighting and various capture hoods provide a high level of operating comfort.



Extraction hoods

Overhead hoods are used for rising media with small particle sizes. They are available in various sizes with different mounting systems and accessories such as louvers or spark arresters.

Side hoods are ideally suited for horizontal or lateral emission sources. The rectangular hoods are versatile in use and can be operated open or equipped with protective or deflection plates.



Extraction tables

Extraction tables are used as workbenches for tasks such as grinding, sawing or welding. They safely and efficiently capture dust, fumes or chips directly at the source. Coarse material falls directly downwards into a discharge bin, while fine particles are captured via the rear or side panels and filtered in an extraction system. Thanks to the flexibly foldable side panels, even large workpieces can be processed without difficulty.

The WT Series extraction tables are ergonomically designed and available in various sizes. They offer numerous options such as LED lighting (also ATEX), hydraulic height adjustment, wheels for mobile use, tool holders, a roof or vice mount. Generous legroom and comfortable operation make them the ideal workbench for clean and safe processing.

Height-adjustable workbench

Ergonomic with generous legroom

Ideal for small series & special parts

Flexibly foldable side panels

Easy discharge & disposal

Individually configurable & expandable

Various worktop options available

Quality »Made in Germany«

WT Series extraction tables are available with various worktop options:



Grating



Plastic



Plasma



Wood

Pre-separators

Pre-separators capture sparks and coarse particles upstream of the filter unit and remove a large proportion of medium-sized and coarse dust at an early stage. This significantly relieves the load on the main filter unit, extends filter service life and noticeably reduces follow-up costs.

ABSAUGWERK pre-separators are suitable for all system types, easy to retrofit and available in various designs. They deliver maximum extraction performance with minimal energy consumption, ensuring efficient and safe extraction over the long term.

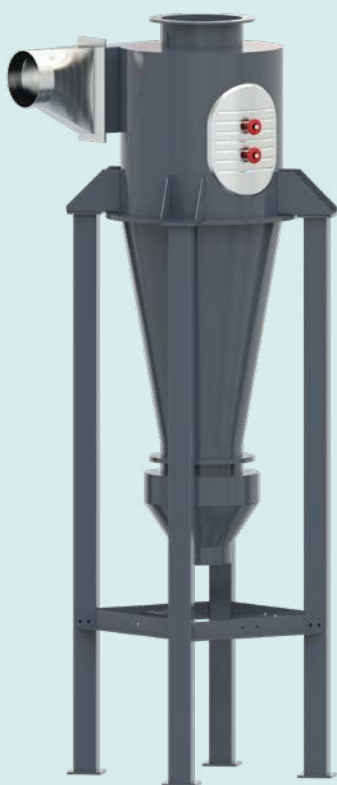

STANDALONE CYCLONE PRE-SEPARATOR

The cyclone pre-separators have been developed using modern flow simulation to achieve optimal airflow velocity and maximum extraction performance. They are available in several versions and can be installed independently next to the system.



SIDE-MOUNTED CYCLONE PRE-SEPARATOR

The side-mounted cyclone pre-separator impresses with its compact and robust design and can be installed directly on the system. It reliably separates coarse particles and sparks, protects the filter system and ensures a longer filter service life.



SPARK PRE-SEPARATOR

The spark pre-separator is installed between the capture system and the pipe system. Due to the reduced air velocity, sparks cool down and are extinguished before reaching the filter system. This minimises the risk of fire and increases operational safety.

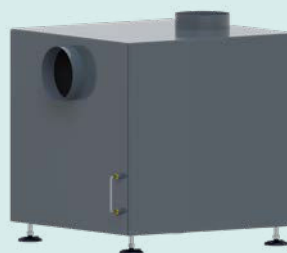

WET PRE-SEPARATOR

In the wet pre-separator, fumes, dust and sparks are bound in a water bath and almost completely extinguished. The high separation efficiency effectively protects the downstream filter system and ensures maximum operational safety.



Fume filter with side-mounted cyclone pre-separator

Custom pre-separator solutions

When processes impose special requirements, customised solutions such as zig-zag pre-separators are required. These deflect sparks and particles several times, causing them to lose energy and extinguish.

In addition, non-return dampers can be combined with the filter system. They prevent dust or odours from flowing back during filter cleaning or system shutdown, ensuring smooth and clean operation.

Every system is different! We are happy to advise you and develop your customised solution.

Discharge systems

The captured media is conveyed to the extraction system via a flow-optimised pipe system, where it is filtered in multiple stages, while the residual material is safely disposed of via a suitable discharge system. Our standard systems can be flexibly expanded with customised solutions tailored to the process, material behaviour and available space.

Depending on the configuration, emptying is either interval-controlled or monitored via level sensors. When the container is full, a notification is automatically issued and the system is safely shut down. This prevents overfilling and ensures long-term operational safety.



ROTARY VALVE

Automatic discharge systems such as rotary valves, double pendulum flaps, screw conveyors, pneumatic conveying systems, discharge slides or shut-off dampers enable time- or quantity-controlled emptying. Discharge can be carried out intermittently or continuously, ensuring reliable continuous operation even with large material volumes.

DRAWER

The drawer discharge is integrated directly into the system, allowing for a particularly compact design. It is ideally suited for very small discharge volumes that can be emptied quickly.

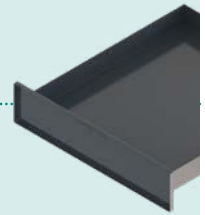

BUCKET

Dust collection buckets with a capacity of 15 or 30 litres offer increased volume and are designed for dust-free disposal thanks to a sealable lid. They are the right choice for small to medium material quantities.



BIN

Bins offer significantly larger capacity and are available in numerous variants – with liner bags, forklift pockets or a tilting mechanism. They are ideally suited for larger material volumes and convenient emptying.



CONTAINER

Container sind für sehr große Austragsmengen ausgelegt und werden oft mit automatischen Aus-
tragssystemen kombiniert. Sie bieten eine effi-
ziente und sichere Entsorgung, selbst bei hohem
Materialaufkommen. Optional erhältlich mit Ölsieb,
Kippvorrichtung oder Rollen für den einfachen
Transport.



DISCHARGES	R 2000	R 3000	R 4000	R 5000	R 6000	R 7000	R 8000
Drawer 50 L	•						
Dust collection bin 50 L	•	•	•				
Dust collection bin 100 L		•	•	•	•	•	•
Bucket 1 x 15 L	•						
Bucket 2 x 15 L		•	•	•	•	•	•
Bucket 2 x 30 L		•	•	•	•	•	•



Extraction cabins

Extraction cabins enable particularly efficient and energy-saving capture, as only a limited air volume needs to be circulated and filtered. Crossflows caused by doors, windows or movements within the hall are significantly reduced, resulting in much more stable capture performance. At the same time, *statutory workplace exposure limits** statutory workplace exposure limits* can be met more easily and cost-effectively. Noise and heat generated by many processes are also effectively contained within the cabin and continuously reduced.



Hall extraction

For large production areas, hall extraction with a central system and pipe system provides comprehensive air cleaning. Multiple workstations can be captured simultaneously and the entire hall air is continuously filtered. This enables the efficient removal of high pollutant loads. In recirculating air operation, the system operates particularly energy-efficiently and sustainably reduces operating costs.

We aim to cover every requirement and, in addition to standard versions, also offer *cost-effective customised solutions.*



** Companies are responsible for ensuring that statutory workplace exposure limits in accordance with TRGS 611, TRGS 900, TRGS 910, etc. are complied with in order to minimise risks to employees.*



SmartX

The **mobile welding fume filter SmartX** provides precise point-of-use extraction directly at the source. Thanks to its compact, robust, and mobile design, SmartX is ideally suited for changing workstations in workshops and production areas, and impresses with easy handling and minimal maintenance requirements.

Separation efficiency of up to 99.9%

Cleanable long-life filters

Easy filter cleaning & filter replacement

Dust-free disposal

Ergonomic operation & maintenance

Compact, space-saving & mobile

Versatile control functions

Large castors for high stability

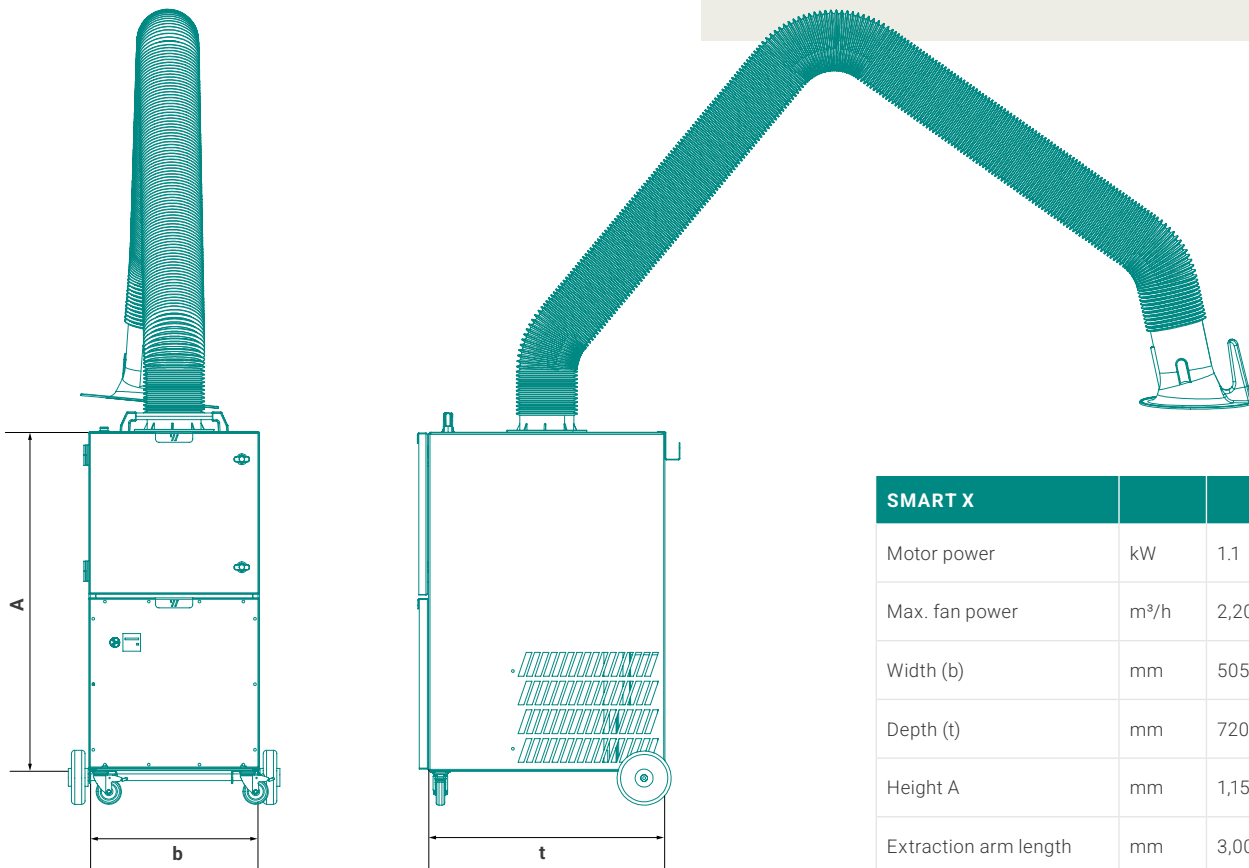

SMART X		
Motor power	kW	1.1
Max. fan power	m³/h	2,200
Width (b)	mm	505
Depth (t)	mm	720
Height A	mm	1,150
Extraction arm length	mm	3,000
Extraction arm Ø	mm	160

Status January 2026 | Subject to change

real. sustainable.

SUSTAINABLE EXTRACTION SOLUTIONS

With their high separation efficiency, our fume filters are ideally suited for *air recirculation mode**, even in processes involving carcinogenic substances. A frequency inverter adjusts the extraction performance according to demand and saves energy. Already during development, we focus on minimal flow resistance and efficient air guidance. The result: powerful systems with very low energy consumption and a particularly durable, sustainable design. In this way, our dust collectors make an important contribution to resource-efficient and energy-efficient production.

RESPONSIBILITY WITHIN THE COMPANY

All of our entrepreneurial activities are based on ecological, social and economic responsibility. Clean air in production halls protects the health of employees, helps prevent illness and makes workplaces safer. At the same time, machinery, tools and workpieces are protected, significantly extending their service life and increasing the economic efficiency of the entire operation.



** The cleaned air is so clean that it can be returned directly to the working environment. An integrated cross-flow heat exchanger uses the heat from the exhaust air for energy recovery, thereby additionally saving heating energy..*

Your benefits

High-quality & durable

Low energy & operating costs

Low maintenance & personnel-friendly

Cleanable permanent filters

Flexible system components

Winter/summer modeg (opt.)

Frequency inverter (opt.)

Cross-flow heat exchanger (opt.)

Primary explosion protection

Ex-Protection

In many industrial processes, flammable or explosive substances such as gases, vapours, mists or dusts are generated. When they come into contact with oxygen and an ignition source, an explosive atmosphere can quickly form, with devastating consequences for people, machines and operations.

ABSAUGWERK extraction systems are designed to prevent the formation of such atmospheres as a preventive measure. Thanks to their high separation efficiency, constant extraction performance, optimal airflow and ATEX-compliant components, they meet the requirements of **primary explosion protection**. At the same time, the specifications of secondary explosion protection are integrated into the system concept. This enables ATEX systems from ABSAUGWERK to be manufactured up to 50% more cost-effectively while sustainably reducing operating and maintenance costs.

Optionally, tertiary explosion protection measures can also be implemented as a supplement.



Legal requirements

Within the European Union, the ATEX Directives govern all requirements and specific aspects of explosion protection. They distinguish between manufacturers and operators, and compliance by both parties is essential to ensure long-term safety and occupational health protection. When designing our extraction systems, we take all relevant parameters into account, assess them in accordance with legal requirements and manufacture ATEX-compliant systems precisely tailored to the respective application.

EC DIRECTIVE	RESPONSIBILITY
2014/34/EU (ATEX 114)	Manufacturer
1999/92/EG (ATEX 137)	Operator

Your benefits

Savings of up to 50%

Low operating & follow-up costs

Maximum extraction performance

Maximum separation efficiency

Safe operation

Highest quality standards

Suitable for indoor installation



Our ATEX systems proactively prevent the formation of explosive atmospheres!

Through various **ATEX measures** and an innovative design, we ensure the safe operation of our systems:

- Air velocity in pipe system ≥ 20 m/s
- Secured airflow monitoring
- ATEX Zone 22 motor or H14 filter upstream of the fan
- Ignition-source-free and conductive design
- No hazardous zones during operation
- Electrical components installed in accordance with ATEX
- Control cabinet located outside the system
- Pre-separator
- Spark detection
- Automatic extinguishing systems in accordance with DIN/EN: water, powder, CO₂
- Automatic system shutdown
- Coated impellers
- Precoat unit (*filter coating*)
- Automatic jet-pulse cleaning (*offline*)
- ATEX-compliant compressed air filter cleaning
- ATEX components (*sensors, discharge systems, etc.*)



Fire protection

An often underestimated risk is not only health-hazardous dust, but also highly combustible dust. Especially when processing aluminium, magnesium, plastics or organic materials such as flour, dust deposits can form in pipe system or filters. If these come into contact with sparks, friction or electrostatic discharge, they can easily ignite.

ABSAUGWERK extraction systems minimise this risk through intelligent airflow design, spark pre-separators and high-quality filter media that prevent ignition sources. Optionally integrated fire protection systems and temperature sensors detect critical conditions at an early stage. This effectively reduces the risk of smouldering, fires or explosions.



Legal requirements

RESPONSIBILITIES OF OPERATORS & MANUFACTURERS

As part of a risk assessment (*suitability of the machines for the intended process*) and the preparation of an explosion protection document, the operator is required to assess whether there is a potential risk of fires or explosions.

The operator is required, as part of a risk assessment (assessment of the suitability of the machines for the intended process) and the preparation of an explosion protection document, to evaluate whether there is a potential risk of fires or explosions.

The manufacturer takes this information into account when defining an appropriate protection concept for the machine tool and aligns the operating and maintenance instructions accordingly.



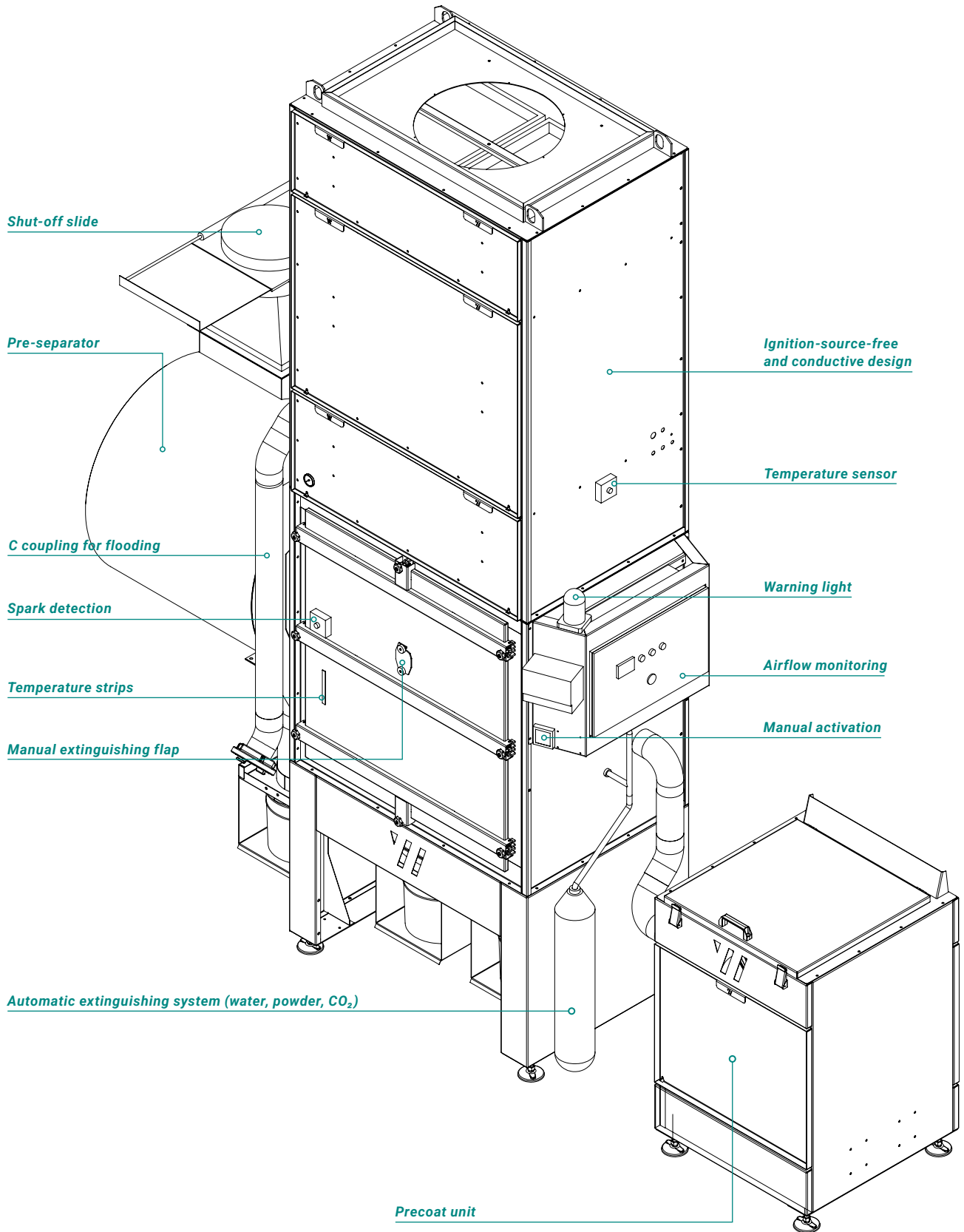

Fire protection components

Noise protection

Noise is one of the most common health risks in the workplace. Continuous exposure can lead to hearing damage, stress and impaired concentration. That is why our extraction systems are designed to operate particularly quietly and can be equipped with additional noise protection components – ensuring that noise exposure remains reliably below statutory limit values.

LIMIT VALUES & MEASURES

A daily noise exposure level LEX,8h **of 80 dB(A)** or a peak sound pressure level LpCpeak **of 135 dB(C)** requires:

- Information for employees
(when the action value is reached)
- Provision of hearing protection
(when the action value is exceeded)
- Offer of occupational medical health surveillance
(when the action value is exceeded)

A daily noise exposure level LEX,8h **of 85 dB(A)** or a peak sound pressure level LpCpeak **of 137 dB(C)** requires:

- Mandatory use of hearing protection
(when the action value is reached)
- Initiation of occupational medical health surveillance
(mandatory surveillance when the action value is reached)
- Identification and marking of noise areas
(when the action value is exceeded)
- Implementation of a noise reduction programme
(when the action value is exceeded)



Legal requirements

Workplace Ordinance
ArbStättV

Noise and Vibration Occupational Safety Ordinance
LärmVibrationsArbSchV

Technical Rules for the Noise and
Vibration Occupational Safety Ordinance
TRLV Noise

Your benefits

Optimised flow geometry

Smooth-running compressors

Maximum extraction performance

Low energy consumption

Noise exposure below 80 dB(A)



We offer a range of specialised **noise protection components** that can be precisely adapted to the process, room size and system performance, including:

- Baffle silencers
- Duct silencers
- Machine enclosures
- Noise protection cabins

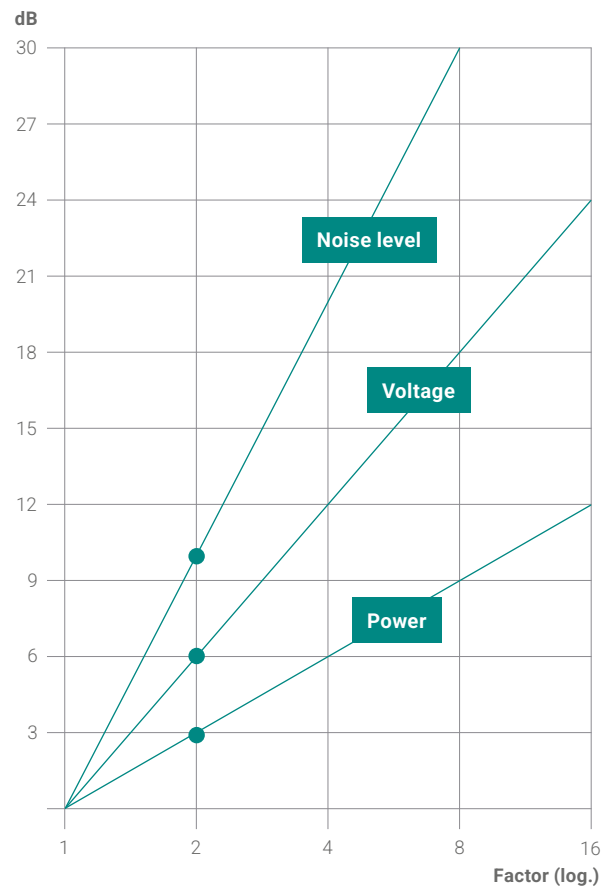

An increase in the noise level of just 3 dB already means a doubling of the sound power and is perceived as significantly louder.

+3 dB = double sound power

+6 dB = double sound pressure

+10 dB = double perceived loudness

Technical Data

7 different size variants

11 power levels



R Series 2000–3000

FUME FILTER SERIES		R 2000	R 2000	R 2000	R 2000	R 3000	R 3000	R 3000	R 3000
Motor power	kW	1.1	2.2	3	4	4	5.5	7.5	11
Max. fan power	m³/h	2,400	3,500	4,500	6,000	6,000	7,000	8,500	15,000
Width (b)	mm	850	850	850	850	1,250	1,250	1,250	1,250
Depth (t)	mm	850	850	850	850	850	850	850	850
Height A (drawer)	mm	860	860	860	1,410	–	–	–	–
Height B (drawer)	mm	2,240	2,240	2,240	2,915	–	–	–	–
Height C (drawer + H14)	mm	2,540	2,540	2,540	3,240	–	–	–	–
Height A (50L bin)	mm	1,165	1,165	1,165	1,715	1,850	1,850	1,850	1,850
Height B (50L bin)	mm	2,560	2,560	2,560	3,220	3,575	3,575	3,575	3,725
Height C (50L bin + H14)	mm	2,895	2,895	2,895	3,535	3,925	3,925	3,925	4,075
Height A (100L bin)	mm	–	–	–	–	2,050	2,050	2,050	2,050
Height B (100L bin)	mm	–	–	–	–	3,775	3,775	3,775	3,925
Height C (100L bin + H14)	mm	–	–	–	–	4,125	4,125	4,125	4,125
Height A (16L bucket)	mm	1,320	1,320	1,320	1,870	1,775	1,775	1,775	1,775
Height B (16L bucket)	mm	2,715	2,715	2,715	3,375	3,500	3,500	3,500	3,650
Height C (16L bucket + H14)	mm	3,050	3,050	3,050	3,690	3,850	3,850	3,850	4,000
Height A (30L bucket)	mm	1,470	1,470	1,470	2,020	1,925	1,925	1,925	1,925
Height B (30L bucket)	mm	2,865	2,865	2,865	3,525	3,650	3,650	3,650	3,800
Height C (30L bucket + H14)	mm	3,200	3,200	3,200	3,840	4,000	4,000	4,000	4,150

Status January 2026 | Subject to change

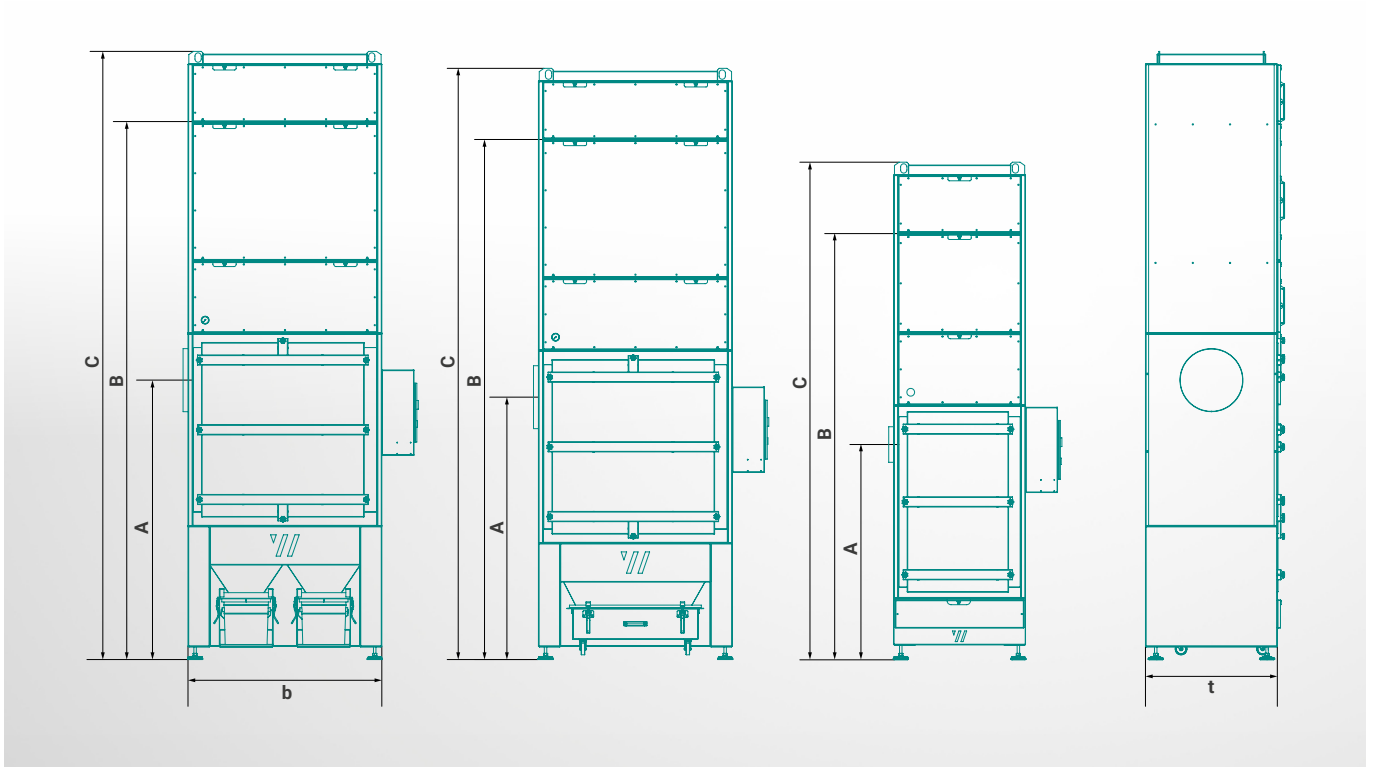

R Series 4000–5000

FUME FILTER SERIES		R 4000	R 4000	R 4000	R 5000	R 6000	R 7000	R 8000
Motor power	kW	15	18.5	22	22	30	37	45
Max. fan power	m ³ /h	18,000	23,000	23,000	23,000	30,500	32,500	36,500
Width (b)	mm	1,250	1,250	1,250	1,840	1,840	2,260	2,260
Depth (t)	mm	1,350	1,350	1,350	1,420	1,840	1,840	2,260
Height A (drawer)	mm	–	–	–	–	–	–	–
Height B (drawer)	mm	–	–	–	–	–	–	–
Height C (drawer + H14)	mm	–	–	–	–	–	–	–
Height A (50L bin)	mm	1,800	1,800	1,800	–	–	–	–
Height B (50L bin)	mm	3,800	4,050	4,050	–	–	–	–
Height C (50L bin + H14)	mm	4,050	4,400	4,400	–	–	–	–
Height A (100L bin)	mm	2,000	2,000	2,180	2,350	2,350	2,350	2,750
Height B (100L bin)	mm	4,000	4,250	4,250	4,575	4,575	4,575	4,575
Height C (100L bin + H14)	mm	4,250	4,600	4,600	5,175	5,175	5,175	5,175
Height A (16L bucket)	mm	2,000	2,000	2,000	2,180	2,350	2,350	2,750
Height B (16L bucket)	mm	4,000	4,250	4,250	4,575	4,575	4,575	4,575
Height C (16L bucket + H14)	mm	4,250	4,600	4,600	5,175	5,175	5,175	5,175
Height A (30L bucket)	mm	2,150	2,150	2,150	2,330	2,500	2,500	2,900
Height B (30L bucket)	mm	4,150	4,400	4,400	4,725	4,725	4,725	4,725
Height C (30L bucket + H14)	mm	4,400	4,750	5,325	5,325	5,325	5,325	5,325

Status January 2026 | Subject to change



Reference

Welding robots and fume filters under a hood at Reisch Fahrzeugbau

Reisch Eliasbrunn GmbH was for many years a leading manufacturer in agricultural and commercial vehicle construction. On a production area of 40,000 m², 250 employees produced up to 168,500 vehicles annually. Reliability and the highest welding quality were always the key focus, particularly for large assemblies in the agricultural and commercial vehicle sector. For a new welding system from Valk Welding, ABSAUGWERK developed a customised extraction solution for two combinable welding robots – despite low ceiling height and high requirements in terms of efficiency and air quality.

»We were surprised at how well the extraction works. The air volume is strong, and the welding fumes are cleanly extracted upwards.«

*Marco Beyer,
Former Plant Manager Reisch Eliasbrunn GmbH*

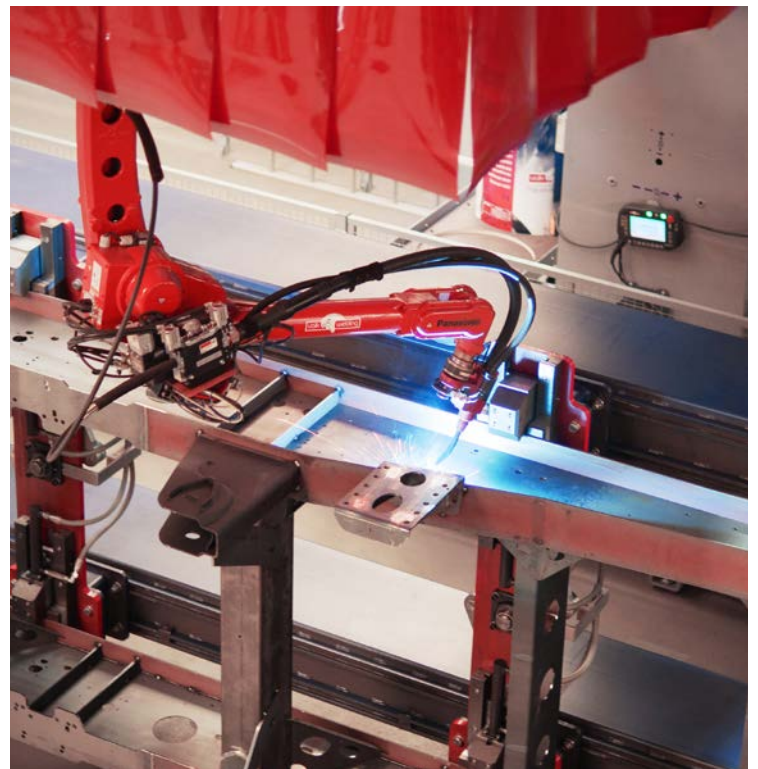

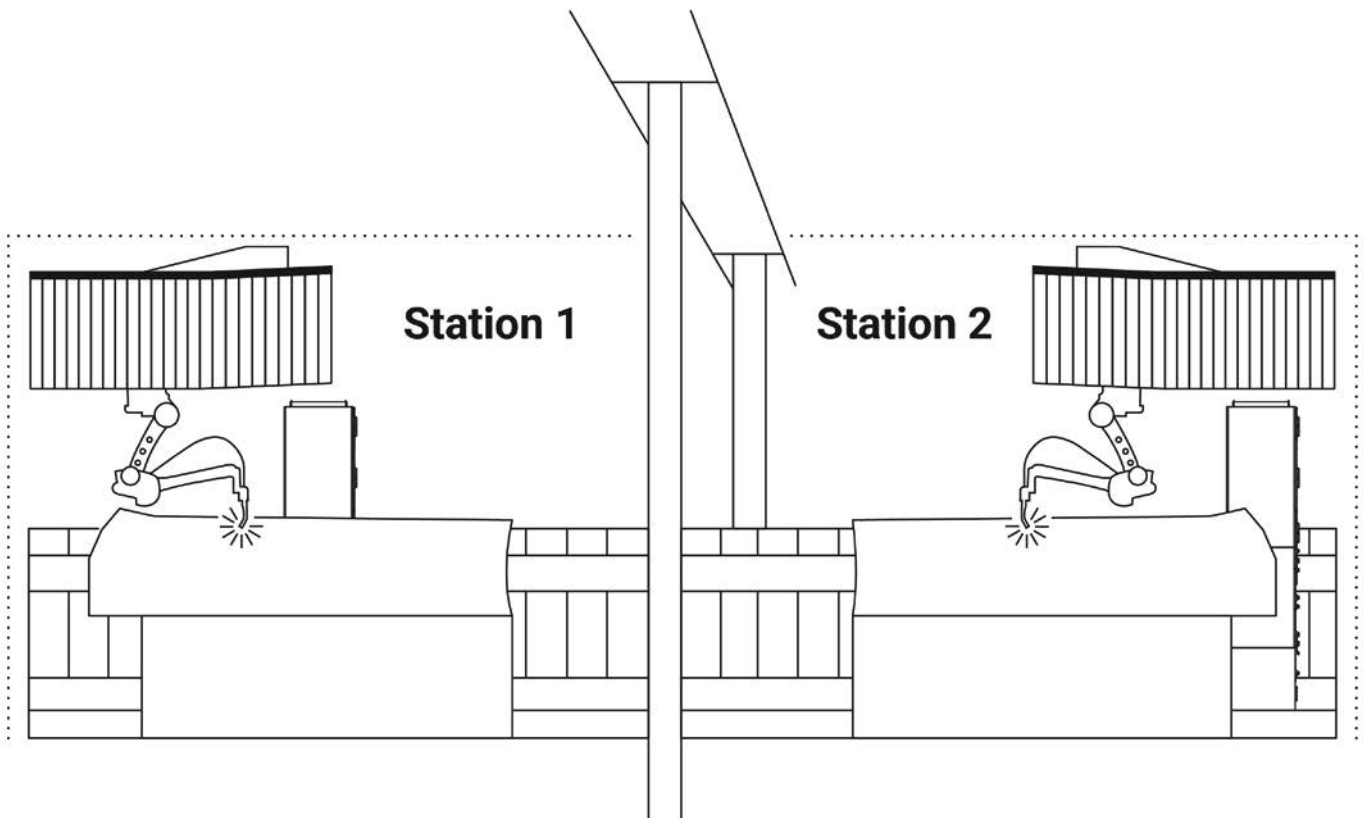

CHALLENGE

A high-performance extraction solution was to be integrated on a robot carriage for two combinable welding robots from Valk Welding. Despite the low ceiling height, efficient fume capture via large-area extraction hoods had to be ensured.

SOLUTION

Two welding fume filters capture the hazardous fumes via large-area, height-adjustable extraction hoods from Valk Welding. Both the extraction systems and the welding robots were mounted on mobile carriages to ensure maximum flexibility in the production process. The pipe system was supplemented with flexible hose elements, allowing the system to move freely without any loss of performance.

Despite a high extraction performance of up to 6,000 m³/h, the filters are compact and lightweight in design. This reduces the energy consumption of the carriages and ensures efficient use of space. The result is a powerful, flexible and energy-efficient welding fume extraction solution that is perfectly tailored to the requirements at Reisch.



The Reisch reference video at
absaugwerk.de/reisch-fahrzeugbau

MEDIA

- Welding fumes

PROCESSES

- Robotic welding

PERFORMANCE

- Motor power: 2 × 4 kW
- Max. airflow: 2 × 6,000 m³/h

SERVICE

Personal consultation, technical design, pipe system planning, production, installation, pipe system, commissioning, maintenance and after-sales support

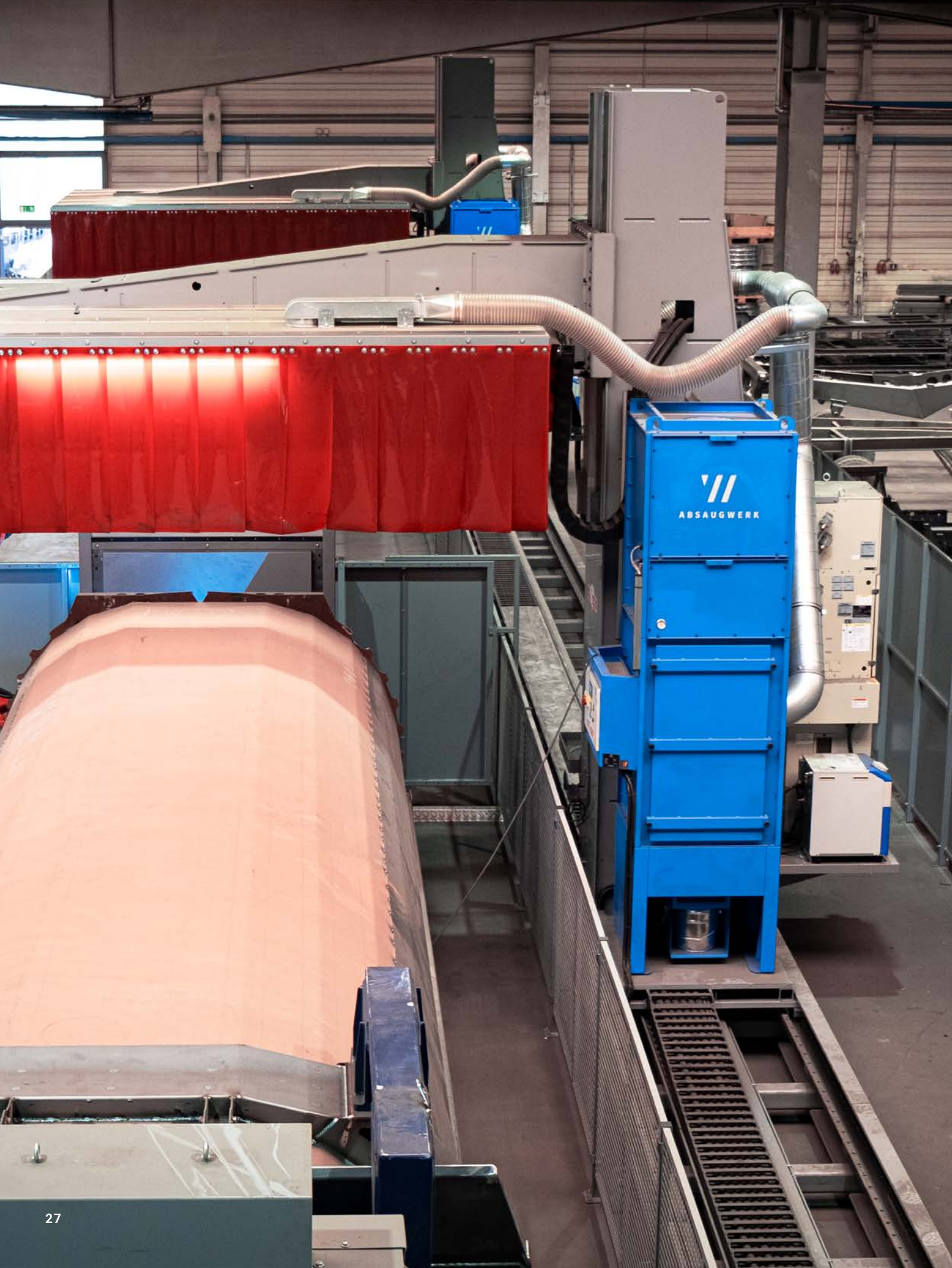



Fig. 1



Fig. 2



Fig. 3



Fig. 4

Fig. 1
2 x R Series 7000, 37 kW

Process: Welding
Material: Carbon steel (oil-free)
Medium: Dry fumes
Capture: Hall extraction, push-pull plus, 10 x extraction arms
Discharge: Dust collection bucket

Fig. 2
R Series 2000, 4 kW

Process: Spot welding
Material: Carbon steel
Medium: Dry fumes
Capture: Canopy hoods, customer-provided
Discharge: Dust collection bucket

Fig. 3
R Series 4000, 18,5 kW

Process: Welding
Material: Carbon steel (oil-free)
Medium: Dry fumes
Capture: Hall extraction, push-pull plus, 6 x extraction arms
Discharge: Dust collection bucket

Fig. 4
Filter unit R 7000, 45 kW

Process: Welding
Material: Carbon steel
Medium: Dry fumes
Capture: Canopy hoods, customer-provided
Discharge: Dust collection bucket

360° all-round service

Consulting

Free needs analysis and individual quotation by our sales team.

Marketing

Support in marketing through videos as well as customised design and branding.

Project planning

Personal support including an on-site inspection and the specification of technical parameters.

Training

Introduction to system components and performance of minor service and maintenance tasks.

We keep your WERK running!

Installation

Delivery and installation of the extraction system, including installation of the pipe system.

After-Sales

The full range: Spare and wear parts, cleaning, training, repairs and retrofitting.

Commissioning

Mechanical and electrical system briefing covering functionality, safety and control.

Maintenance

Comprehensive service for third-party and in-house systems to ensure smooth operation.

Your benefits

Everything from a single source

In-house & third-party maintenance

Free process analysis

Personal on-site appointment

Smooth & safe operation

Avoidance of downtime & follow-up costs

Worldwide support

Remote diagnostics & maintenance

Maintenance

Unplanned system downtime can not only cause high costs, but also put employee safety at risk. To ensure that your extraction systems operate efficiently and reliably over the long term, ABSAUGWERK offers a comprehensive maintenance service. Regular inspections allow technical deviations to be identified at an early stage, before they develop into costly or safety-critical issues. Our many years of expertise and a well-structured service organisation ensure short response times and rapid fault resolution.

REMOTE MAINTENANCE – WORLD WIDE WERK

In automated production environments, reliability is essential. Our remote maintenance systems monitor system parameters in real time and automatically notify us of critical deviations. This enables our service technicians to respond immediately, regardless of location. Intelligent monitoring, modern alarm functions and secure VPN encryption provide fast support, protect your data and offer maximum flexibility at the same time.

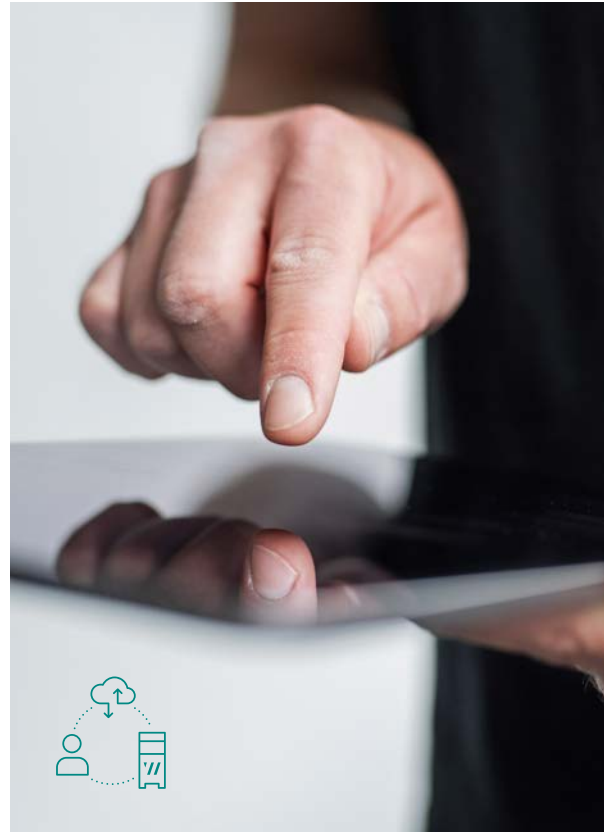

We service both in-house and third-party systems.
You only need one appointment and one site visit!

Request your non-binding maintenance offer:

sales@absaugwerk.de





Quality from Neu-Ulm!

Our WERKER are professionals in their field and see themselves as part of the overall WERK. With more than 200 years of combined experience in extraction technology, we create durable and robust extraction systems handcrafted and »MADE IN NEU-ULM«! Every system undergoes strict quality and safety testing before it leaves our WERK.

We continuously invest in training and technology to keep moving the market forward. Our innovative strength has been recognised with the BSFZ seal – a mark of research-based development and publicly funded innovation. Our goal: better working conditions, sustainable environmental protection and your success with perfect workpieces.

We configure extraction systems individually and provide premium service directly from our WERK. That's what makes our solutions **real. better.**



Every WERKER considers themselves part of a responsible society and a healthy environment.



Learn what matters in extraction technology!

Effective extraction is essential for safe and healthy working environments. We inform you about relevant workplace exposure limits and legal requirements, and show you which solutions best suit your processes.

You will also get to know the various components of our systems: we explain what matters in system design, planning and maintenance, and provide practical tips for minor service tasks.

For our OEM and distribution partners, we offer customised training programmes, either directly at your site or at our WERK in Neu-Ulm.

Feel free to contact us:

info@absaugwerk.de | +49 731 141 108-0

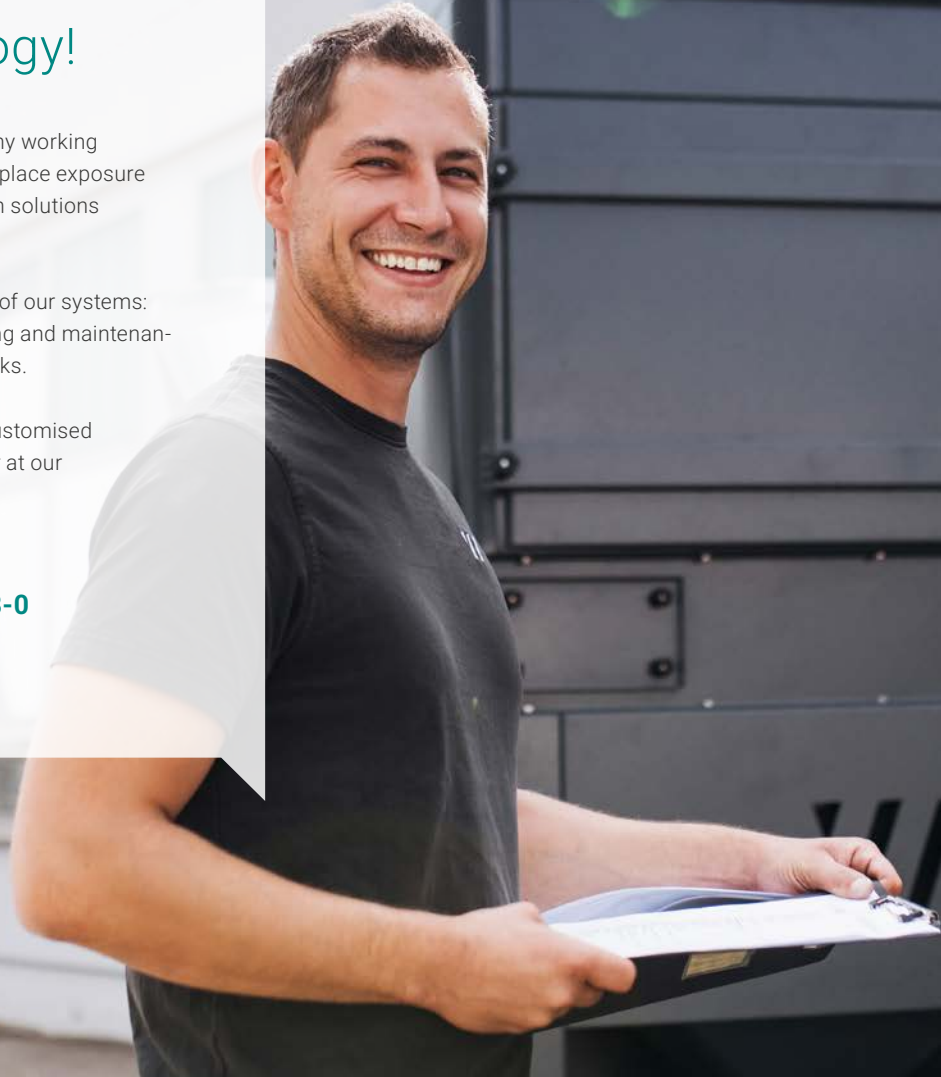

real. personal.

ABSAUGWERK stands for lived values that go far beyond technology. Our employees share not only expertise, but also common values of teamwork, responsibility and trust. This culture forms the foundation of our success and our »feel-good philosophy«.

Within our network, we also focus on genuine partnerships: open, respectful and on equal footing. We believe in long-term relationships built on reliability and mutual appreciation, because only together can something be created that truly lasts.

ABSAUGWERK GmbH
Messerschmittstr. 22
DE-89231 Neu-Ulm

+49 731 141 108-0
info@absaugwerk.de
www.absaugwerk.de

Follow us on social media:



[@ABSAUGWERK GmbH](https://www.instagram.com/absaugwerk)



Project process

5 steps to your perfect extraction solution!

- **01** **Process analysis**

In the first step, your work processes are analysed, pollutant sources are identified and existing extraction systems are reviewed in order to determine the exact extraction requirements.
- **02** **Personal on-site visit**

Our experts assess the local conditions directly at your site and take precise measurements to plan the ideal solution for your operation.
- **03** **Individual quotation**

Based on the analysis and technical drawings, you will receive a customised quotation within a short time, offering the most economical solution for your needs.
- **04** **Production**

Once the technical drawings have been approved and the order placed, we immediately begin procurement, manufacturing and scheduling for installation.
- **05** **Installation**

Our installers set up the complete extraction system, including pipe system, and support you during commissioning. Performance and functionality are carefully tested and documented – ensuring a smooth start-up.



absaugwerk.de

real. better.